



HOLMARC manufactures state of the art UV-VIS-NIR full range spectrometers, spectrophotometers, and analytical systems for laboratory and research use.

HOLMARC UV-VIS-IR Spectrometers



7



Spectroscopy

HOLMARC now manufactures a range of spectroscopic products utilizing its capabilities in optics and holographic gratings. There are custom as well as standard spectroscopic products which find frequent applications in industry as well as research laboratories. What we see as our strength is our ability to customize these products quickly and economically.



CONTENTS

Spectrometer Goniometer RE-01	322
Spectrometer Goniometer RE-02	323
Spectrometer Goniometer - Researcher Version	324
Scattering Photometer-Single Channel Light Detection	326
Scattering Photometer - Spectral Light Detection	327 NEW
CT216 Series Compact CCD Spectrometer	328 NEW
CG216 Series Compact CCD Spectrometer	329 NEW
USB 2.0 Spectra CD 214 Spectrometer	330
UV-VIS-NIR Scanning Spectrometer	331
CCD based Stitched Scanning Spectrometer	332 NEW
CCD based Multi Channel Scanning Spectrometer	333 NEW
Spectra Standard Monochromators UV-VIS-NIR	334
Mini Monochromator	335 NEW
Manual Mini Monochromator	335
Spectra Quasar Series Scientific Monochromators	336 NEW
High Throughput DUAL Grating f/3.5 Monochromator	338
LASER RAMAN Spectrometer(PMT Based)	339
CCD Based LASER Raman Spectrometer(Compact Model)	340 NEW
LASER Raman Spectrometer Model : HRRS 216R2	341
Confocal LASER RAMAN Spectrometer	342 NEW
FLUORESCENCE Spectrometer	343
Accessories for SPECTRA Instruments	344
Light Sources	345
Broadband Light Sources	346
LASERS	348
Diode Laser	348
DPSS Lasers	349
Helium Neon Lasers	350
Spectroscopic Line CCD camera Module	351 NEW
Standard Lens Adaptor for Spectroscopic Line	
Enclosed CCD camera Module	353
High Sensitivity Cooled CCD Camera	353
Optical Modulator & Isolators	354
Faraday Modulator - Polarization Modulation	354 NEW
Faraday Isolator (Optical Isolator)	355 NEW
Optical Chopper	355
SMA 905 0.22NA FUSED SILICAFiber optic patchcords	356
SMA 905 PMMA 0.5NAFiber optic patchcords	356
Rectangular to Circular Fiber Patchcords	357 NEW
Reflectance Probes	358 NEW
Reflectance Probe Stands	359

HOLMARC OPTO-MECHATRONICS PVT.LTD

Plot No. B.7, H.M.T. Industrial Estate, H.M.T. P.O. Kalamassery
Kochi, Kerala, India, PIN : 683 503, Ph: 91-484-2540075

All Products are manufactured and marketed by
HOLMARCTM Opto-Mechatronics Pvt. Ltd



271 LABORATORY EQUIPMENTS

321 SPECTROSCOPY

361 IMAGING DEVICES

393 HOLOGRAPHY

399 PHYSICS LABS INSTRUMENTS

416 INDEX

Spectrometer Goniometer-Rail based

Model : HO-SP-RE-01

Features

Modern & user friendly design
Numerous supporting accessories...
Include Comprehensive manual.

Model : HO-SP-RE-01 Include
Spectrometer Goniometer
Equilateral High Index Prism
Hollow Prism
Diffraction grating
Mercury Lamp with Power Supply



Application Include

Spectroscopy

Emission spectrum
Absorption spectrum
R.P of grating & prisms
Dichroism etc.

Angle measurements of equilateral prism, wedge prism, biprism etc.
Refractive index measurements.

Diffraction

Determination of
Groove spacing
Wavelength
Biprism diffraction etc.

Measuring Optical Parameters like

Optical density
Reflectivity
Transitivity
Absorption
Polarization angle etc.

Resolution

Prism Table : 10 arc minute
Telescope Positioning : 1 arc minute

Slit

Design : Variable, 0-3mm
Micrometer controlled
Resolution : 10 Micron



Spectrometer Goniometer (Model No: HO-SP-RE-01) is designed as a versatile instrument suitable for any optics laboratory. Its optical rail based construction allows the user to device it for multitudes of applications. Laser engraved, precise rotary graduations ensure reliable and repeatable read outs. Its sturdy movement along with its fine positioning capabilities makes the instrument suitable for many research activities other than spectroscopy.

The measurement of refractive index is carried out with a dispersion prism made from the material to be tested. For the measurement of fluids, a hollow prism, which is filled with the fluid is used. The optical parameters like optical density, reflectivity, transitivity, absorption, polarization angle etc. are determined with the help of a photo diode detector. It can also be used as a spectroscope for qualitative examination and measurement of emission and absorption spectra. The diffraction angle of plane grating and holographic grating can also be measured. Various accessories and mounting options are available.



All components are made of aluminium and stainless steel to avoid corrosion. Optics used are of research quality. The slit used is of precision grade with micrometer adjustments for sub-micron sensitivity. The well designed mechanics of the Goniometer allows maintenance-free operation over many years.

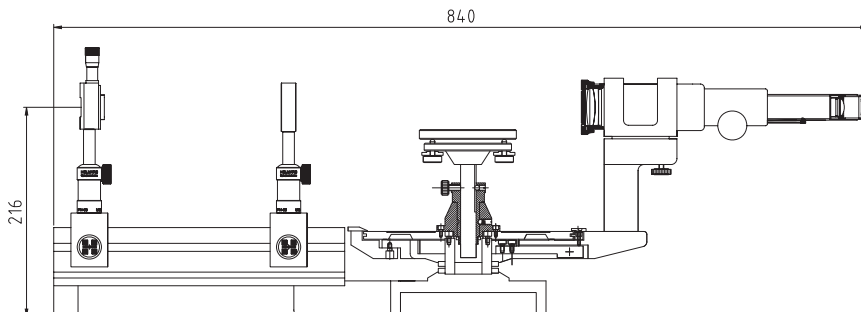

The instrument can be used for inspection of various optical components in laboratories or workshops.

Open and flexible design facilitates quick modification of the instrument for custom applications. This goniometer can also be used for checking reflection & transmission ratios of thin films coated on glass substrate.

Spectrometer Goniometer

Model : HO-SP-RE-02

Features

Precision Optical Instrument
Modern & user friendly design.
Research Grade Construction.
Numerous supporting accessories...
Include Comprehensive manual.



Model : HO-SP-RE-02 Include
Spectrometer Goniometer
Equilateral High Index Prism
Hollow Prism
Diffraction grating
Mercury Lamp with Power Supply



http://www.holmarc.com/spectrometer_goniometer_2.php

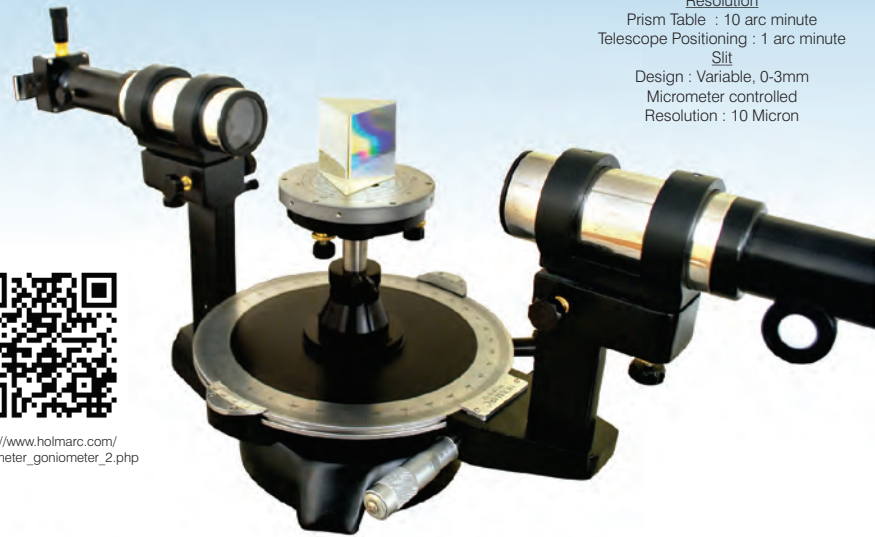

Resolution
Prism Table : 10 arc minute
Telescope Positioning : 1 arc minute
Slit
Design : Variable, 0-3mm
Micrometer controlled
Resolution : 10 Micron

Spectrometer Goniometer Model No: HO-SP-RE-02 has conventional design where slit along with collimator is fixed on a tilt adjustable holder instead of rail and carriage as in Model No: HO-SP-RE-01 described in the preceding page. This spectrometer is well suited for all general purpose applications including the analysis of spectrum of light sources, characterization of prisms and gratings, etc. A precision rotation stage with coarse and fine movement holds the telescope. There are two rotation stages, concentrically assembled, one for telescope and other for the sample. The 216mm graduated disc features a 360° scale with divisions of 0.5° and two vernier scales separated by 180°. The vernier scale has an accuracy of 1 angular minute. The prism table is removable and features three point leveling screws and 50mm height adjustments.

The measurement of refractive index is carried out with a dispersion prism made from the material to be tested. For the measurements of fluids, a hollow prism, which is filled with the fluid is used. The optical parameters like optical density, reflectivity, transitivity, absorption, polarization angle etc. are determined with the help of a photo diode detector. It can also be used as a spectroscopy for qualitative examination and measurement of emission and absorption spectra. The diffraction angle of plane grating and holographic grating can also be measured. Various accessories and mounting options are available.

All components are made of aluminium and stainless steel to avoid corrosion. Optics used are of research quality. The slit used is of precision grade with fine lead screw adjustments for sub-micron sensitivity. The well designed mechanics of the Goniometer allows maintenance-free operation over many years.

This goniometer can be used for precision measurements of the optical data on prisms. It can also be used as a spectroscopy for qualitative examination and measurement of emission and absorption spectra. Numerous accessories are available.

Various detectors are available for goniometer. Optical parameters in the UV-VIS-IR range can be determined with the help of suitable detector unit. We can provide special detector heads for goniometer. You are welcome, to discuss your application requirements with us.

Precision Adjustable Slit

Precision Adjustable Slit will be provided with RE-02 Research Goniometer

Model : HO-ED-PS6



Micrometer controlled slits
Width : 0-3mm-continuously variable
Height : 10mm
Construction : Metallic (non corrosive)

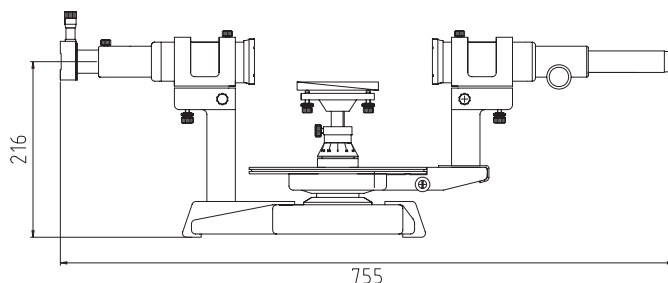

Spectrometer Goniometer Advanced Researcher Version-RE03DM UV-VIS-NIR Detector Based Measurements



Model : HO-SP-RE-03DM



0.001 Degree
POSITIONING RESOLUTION



For precise determination of angular position, particularly for the optical spectra applications, Holmarc has introduced a new high precision 0.0001 degree resolution spectrometer goniometer. It features low dark current linear Si-Photodiode detection unit for low light measurements. This allows users to work with the spectrometer goniometer in the wavelength range of 320-1100 nm (UV-VIS-NIR). This instrument is suitable for custom experiments and inspection of various optical components with precision. Open and flexible design facilitates quick modification of the instrument for custom applications.

Application Include

Spectroscopy

Emission spectrum
Absorption spectrum
R.P of grating & prisms
Dichroism etc.

Angle measurements of equilateral prism, wedge prism, biprism etc.
Refractive index measurements.

Diffraction

Determination of
Groove spacing
Wavelength
Biprism diffraction etc.

Measurement of Optical Parameters

Optical density
Reflectivity
Transitivity
Absorption
Polarization angle etc.

This instrument can as well be used as a spectroscope for the observation and measurement of emission and absorption spectra. Other applications include measurement and determination of optical angles of prisms, thin film characterization through the measurement of reflection and transmission, Brewster's angle spectroscopy etc. When used with a prism, it helps to observe visible light dispersed by wavelength. When used with a diffraction grating and a gas discharge tube, we can observe the emission spectrum of various gases. The wavelengths of each electron transition in the spectrum can be calculated according to the angle of deflection of the light reflected by the grating.

Features:

Removable collimator and telescope tubes
Custom Accessories
Horizontal and vertical adjustments for collimator & telescope
Precision slit 0-3mm adjustable with 10micron resolution
Slit height is adjustable from 0 - 10 mm
Fiber optic coupling unit

Specifications :

Telescope & Collimator Tube : 200mm Focal length
Aperture : 30mm
Detector Unit : Linear Si Photodiode
Software : Spectra RE scanning Soft. Version 1.020
Rotation : 360 Degree Continuously Rotatable
Telescope and Sample
Design : Precision Worm gear with double bearing
Resolution : 0.001 Degree for Telescope
0.05 Degree for Sample Plate
Marking : Graduated rotary scale for visual reference
Construction : Aluminium
Finish : Black anodized

Focal length of the telescope and collimator tube is 200 mm. Graduated disc features a 360 degree scale with divisions of 0.5. The prism table is removable and features three point bearing leveling screws.

Detector Unit

High precision low dark current (5pA) linear Si-Photodiode with active area of 1.1x5.9mm is used as detector in RE03DM Spectrometer Goniometer. It has spectral range of 320-1100nm.

Custom spectral/optical experiments using Theta Two Theta Goniometer

Holmarc's theta 2 theta stage consists of two rotation stages arranged in such a way that axis of rotation for both the stages are same. Both stages have preloaded ball bearing guides for wobble free rotation and positioning. 360° limitless movement is possible for inner and outer stages. Holmarc manufactures these stages with manual as well as motorized drive configurations.

Rotary graduations are provided in 1°/ 2° with appropriate vernier graduations depending on the size of the stage. For motorized rotation stage, worm and gear is our standard drive mechanism. Surfaces of both stages are provided with M6 tapped holes for mounting components and sub-assemblies. Holmarc manufactures custom theta 2 theta stages to suit specific applications as well.

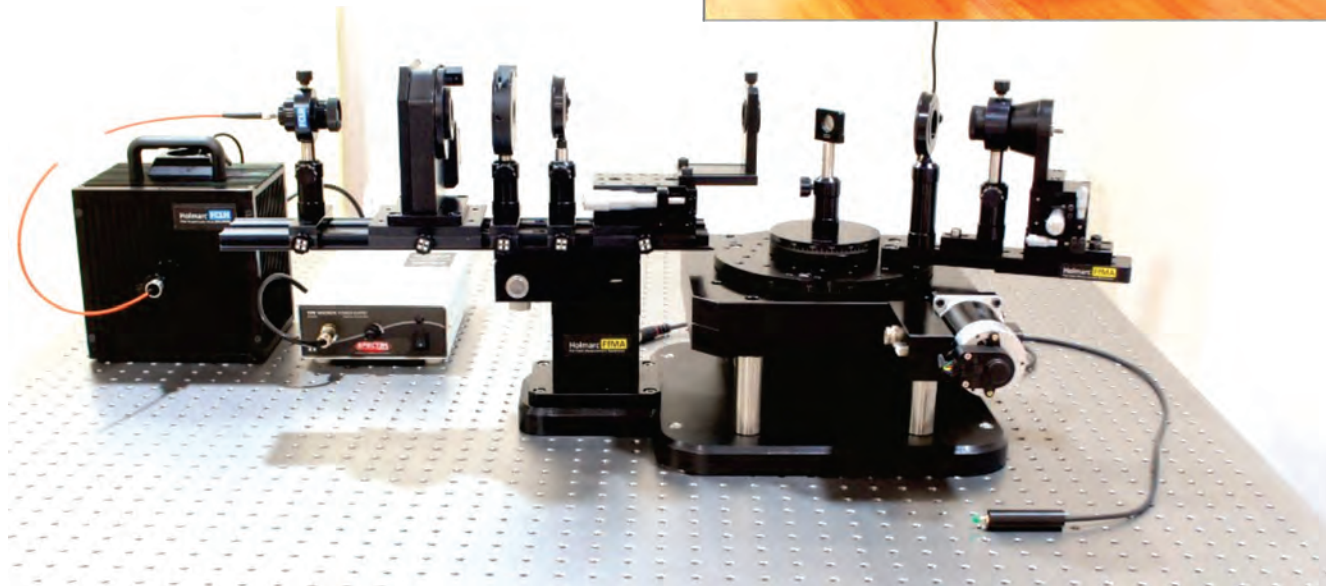

Fiber Coupled Tungsten Lamp

USB Spectrometer

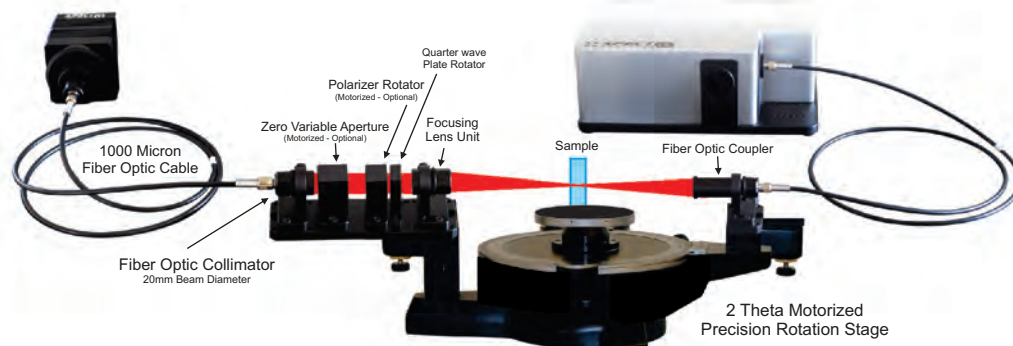

HOLMARC manufacture hundreds of standard as well as custom products to suit various customer applications. What makes us different from other manufacturers is the installation and after sales support that we provide.

We also offer assistance to students and researchers in their project work. This is possible only because of our years of experience and research in various disciplines.

For more products and information,

visit us @ www.holmarc.com

Contacts

>> mail@holmarc.com Tel: 91-484-2540075
>> sales@holmarc.com Fax: 91-484-2540882

Follow us on



Scattering Photometer - Single Channel Light Detection

MODEL : HO-IAD-SG-01

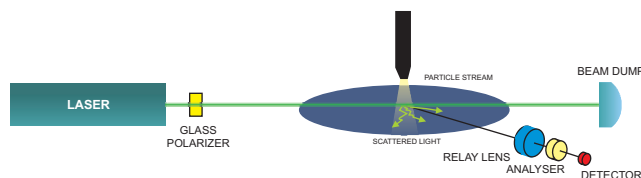
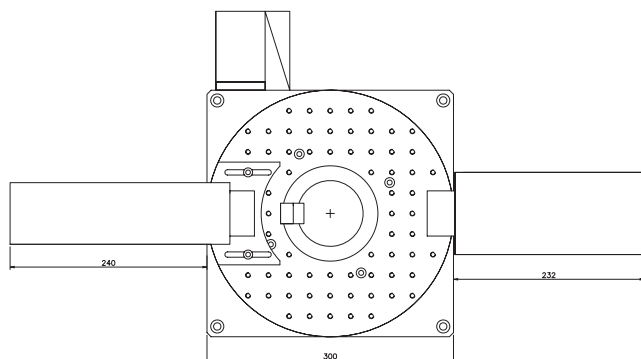

Laser source is mounted on a precision rotation stage with central access hole. The stage is driven by stepper motor. Sample is introduced through the center hole of the stage. As the stage along with the laser source rotates, output data from the detector is collected automatically and saved in the computer with reference to the angular position of the rotation stage.

Note : MODEL : HO-IAD-SG-01 comes with 100mW DPSS 532nm laser with APD Detector. Other laser and detectors can also be integrated with the system as per custom requirements.



A scattering photometer for measuring the intensity of light scattered by particles has been developed by Holmarc for environmental research. It is a precision instrument designed for spectroscopic measurements of scattered light. This goniometer based instrument provides controlled multi angle measurement of particles.

A 100mw laser beam (532nm) is directed first to a linear polarizer and then into a scattering compartment containing the particles under study. The scattered light is focused onto APD (Avalanche Photo Diode) detector to generate an electrical signal indicating the amount of scattered light at that position. The motorized rotation stage helps to take reading at different angles. The entire operation is automated through a personal computer. Custom developed software and interfacing electronics are supplied along with the system.

GONIOMETER SPECIFICATIONS

Resolution	: 0.01 degree.
Maximum Speed	: 10 degree/sec
Traverse	: 280°
Actuator	: Stepper Motor (DPM60SH86-2008AF)
Load Capacity	: 50 Kg.
Material	: Aluminium
Turn table dimension	: 500X500X65mm.
Net. Weight	: 37Kg.

ROTATION STAGES

Holmarc manufactures goniometers and rotation stages in variety of standard designs for a wide range of applications. Size of these stages can range from 50 mm to 500 mm in diameter. Construction material can be aluminium alloy, mild steel, stainless steel or brass depending on the application.

MICRO POSITION CONTROL & SOFTWARE

Programmable stepper/bldc motor controllers and drives are available as standard products from Holmarc.

Please feel free to contact us at sales@holmarc.com



Scattering Photometer - Spectral Light Detection

MODEL : HO-IAD-SG-02



Spectrometer(MODEL : HO-IAD-SG-02) has been developed for measuring the intensity of light spectrum (ranging from 350-1050nm) scattered by particles. It is a precision instrument designed for research applications where spectroscopic measurements need to be carried out from scattered light. Goniometer based design helps in multi angle spectral measurements .

A 50W fiber coupled quartz halogen lamp is used as the light source for scattering measurements. Light from the optical fiber is collimated using a precision lens system and directed to a linear polarizer and then into a scattering compartment/sample chamber containing the particles under study. The scattered light is focused onto a fiber optic cable connected to a compact CCD spectrometer. Software provided with the spectrometer analyze the amount of scattered light at different wavelength and position. The motorized rotation stage helps to take the reading at different angles. The entire operation is automated through a personal computer. Custom developed software and interfacing electronics are supplied along with the system.

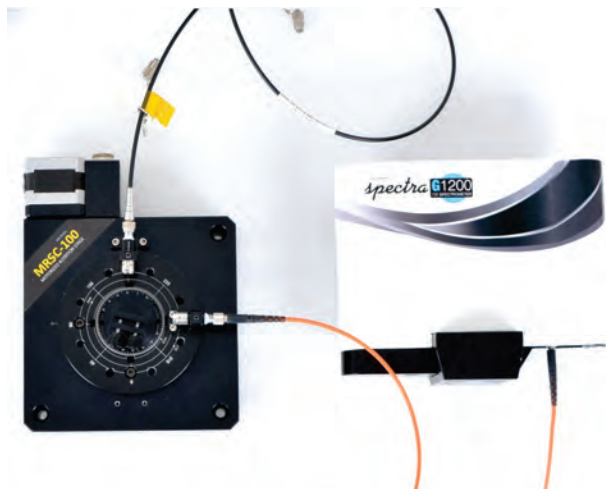

GONIOMETER SPECIFICATIONS

Resolution	: 0.05 degree.
Maximum Speed	: 10 degree/sec
Traverse	: 280°
Actuator	: Stepper Motor (DPM60SH86-2008AF)
Load Capacity	: 10 Kg.
Material	: Aluminium
Turn table dimension	: 150X150X50mm.

SOURCE SPECIFICATIONS

Lamp	: Quartz Halogen
Wattage	: 50W
Wavelength range	: 340-2700nm
Powersupply	: Constant Current SMPS
Supply	: Fixed
Lamp Housing	: Forced Air Cooled Type
Optics	: Concave metallic mirror
Construction	: Aluminium black Anodized

SPECTROMETER SPECIFICATIONS

Spectrograph f#	2.9
Optical Platform	Concave Grating
Spectral Range	350 to 1050nm
Spectral Resolution	1nm
Slit Options	Micrometer Controlled Variable Slit
Input Fiber Connector	SMA 905 [FC (Optional)]
Input Fiber NA	0.22
Stray Light	<0.06% @ 532nm (<0.1% overall)
Detector	Toshiba TCD1304AP Linear CCD Array
Pixel Number	3648
Pixel Size	8x200µm
Pixel Well Depth	100,000electron
Signal-to-noise Ratio	1,000:1(at full scale)-
A/D Resolution	16 bit
Integration Time	0.1 to 6,500 ms
Frame Rate	up to 138 fps
Trigger Input	Yes, Optional
PC interface	USB 2.0
Software	Spectra ANALYTE Includes DLL libraries and SDKs for easy custom application development

FIBER SPECIFICATIONS

Wavelength Range	: 190 - 1600nm
Connector	: SMA
Numerical Aperture NA	: 0.22
Acceptance Angle	: 25.4°
Operating Temperature	: -40 to +100°C
Length	: 1.5m

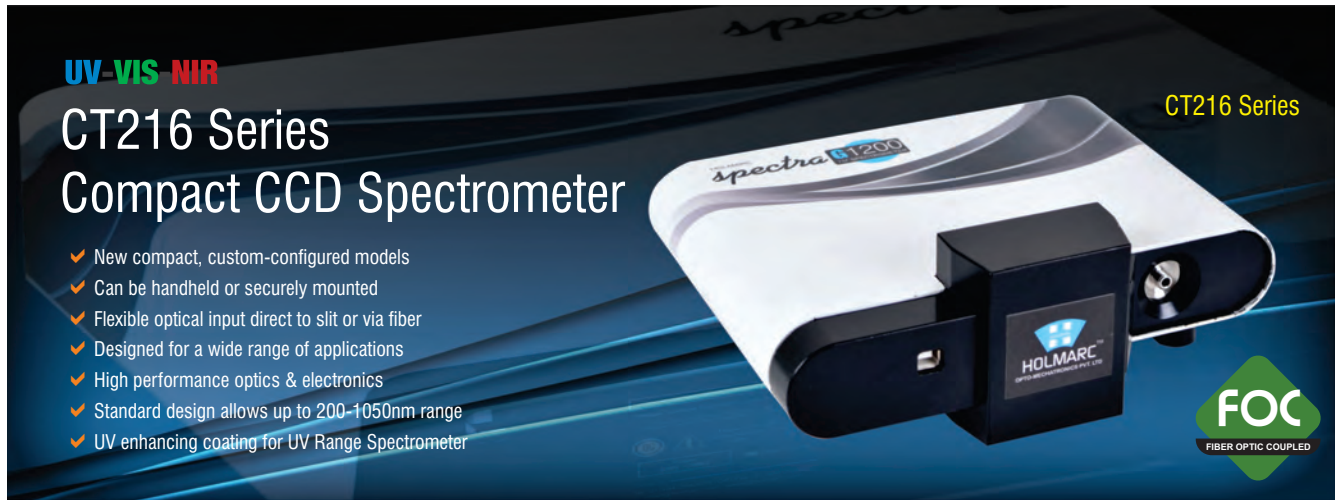

Perfect Choice for Spectral Applications



The CT216 Series spectrometers are cost-effective high-performance CCD based instruments designed for use with a PC. The standard sensor arrays used in the spectrometer is Toshiba TCD1304DG B/W board-level line CCD camera, based on a single-line, 3648-pixel CCD chip. The array driver electronics has been developed by Holmarc and designed for highly sensitive yet stable operation.

More pixel numbers in the sensor makes the CT216 Series spectrometers more suitable for the applications requiring high resolution. Thanks to high sensitivity of the CCD, the spectrometer can be used for applications with low light signals as well. It can accept light directly through its built-in slit or via optical fiber. UV spectrometer uses windowless CCD to increase the UV sensitivity down to 200nm. It helps the signal sensitivity below 380nm get improved ~20-50% more in general.

The CT216 Series spectrometers are custom-wavelength range configured models which can be tuned to desired spectral range wavelength for custom applications. Spectral resolution can be down to 0.05nm.

High-Resolution, Customizable Spectroscopy Platform

CT216 Series spectrometer uses f/4 Czerny - Turner design with plane grating for spectral dispersion. Standard interface to the CT216 Series spectrometers is USB 2.0 compatible with 16-bit extended dynamic range. Software support includes SDK and DLLs for dedicated applications development and Spectra QSR Windows-based spectral acquisition and analysis package.

CT216 CCD Spectrometers specification

Model	HO-CT216-UV	HO-CT216-3582	HO-CT216-4065	HO-CT216-2010	HO-CT216-3010
Wavelength Range	200 ~ 400nm	350 ~ 820nm	400 ~ 650nm	200 ~ 1050nm	300 ~ 1,050nm
Resolution*	0.25nm	0.45nm	0.27nm	1nm	0.9nm
Spectrograph f#	4				
Optical Platform	Czerny-Turner				
Effective Spectral Range	200 to 1050nm				
Spectral Resolution	0.1 to 1nm depending on choices				
Slit Options	Micrometer Controlled Variable Slit or 10, 15, 20, 25, 50, 100, 200 or 400µm Fixed Slits				
Input Fiber Connector	SMA 905 [FC (Optional)]				
Input Fiber NA	0.22				
Stray Light	<0.06% @ 532nm (<0.1% overall)				
Detector	Toshiba TCD1304AP Linear CCD Array				
Pixel Number	3648				
Pixel Size	8x200µm				
Pixel Well Depth	100,000electron				
Signal-to-noise Ratio	1,000:1 (at full scale)-				
A/D Resolution	16 bit				
Integration Time	0.1 to 6,500 ms				
Frame Rate	up to 138 fps				
Trigger Input	Yes, Optional				
PC interface	USB 2.0				
Software	Spectra Analyte V2.26 (free with spectrometer) Includes DLL libraries and SDKs for easy custom application development				





UV VIS NIR

CG216 Series Compact CCD Spectrometer

- ✓ New compact, custom-configured models
- ✓ Can be handheld or securely mounted
- ✓ Flexible optical input direct to slit or via fiber
- ✓ Designed for a wide range of applications
- ✓ High performance optics & electronics
- ✓ Standard design allows up to 200-1050nm range
- ✓ UV enhancing coating for UV Range Spectrometer

CG216 Series

FOC
FIBER OPTIC COUPLED

Perfect Choice for Spectral Applications



The CG216 Series spectrometers are cost-effective high-performance CCD based instruments designed for use with a PC. The standard sensor arrays used in the spectrometer is Toshiba TCD1304DG B/W board-level line CCD camera, based on a single-line, 3648-pixel CCD chip. The array driver electronics has been developed by Holmarc and designed for highly sensitive yet stable operation. More pixel numbers in the sensor makes the

CG216 Series spectrometers more suitable for the applications requiring high resolution. Thanks to high sensitivity of the CCD, the spectrometer can be used for applications with low light signals as well. It can accept light directly through its built-in slit or via optical fiber. UV spectrometer uses windowless CCD to increase the UV sensitivity down to 200nm. It helps the signal sensitivity below 380nm get improved ~20-50% more in general.

CG216 Series spectrometer uses f/4 Czerny - Turner design with concave grating for spectral dispersion. Standard interface to the Cg216 Series spectrometers is USB 2.0 compatible with 16-bit extended dynamic range. Software support includes SDK and DLLs for dedicated applications development and Spectra QSR Windows-based spectral acquisition and analysis package.

CG216 CCD Spectrometers Specification

Model	HO-CG216-2075	HO-CG216-4010	HO-CG216-3290
Wavelength Range	200 ~ 750nm	400 ~ 1000nm	320 ~ 900nm
Resolution*	0.95nm	0.75nm	0.9nm
Spectrograph f#	2.9		
Optical Platform	Concave Grating		
Effective Spectral Range	200 to 1050nm		
Spectral Resolution	0.1 to 1nm depending on choices		
Slit Options	Micrometer Controlled Variable Slit or 10, 15, 20, 25, 50, 100, 200 or 400µm Fixed Slits		
Input Fiber Connector	SMA 905 [FC (Optional)]		
Input Fiber NA	0.22		
Stray Light	<0.06% @ 532nm (<0.1% overall)		
Detector	Toshiba TCD1304AP Linear CCD Array		
Pixel Number	3648		
Pixel Size	8x200µm		
Pixel Well Depth	100,000electron		
Signal-to-noise Ratio	1,000:1(at full scale)-		
A/D Resolution	16 bit		
Integration Time	0.1 to 6,500 ms		
Frame Rate	up to 138 fps		
Trigger Input	Yes, Optional		
PC interface	USB 2.0		
Software	Spectra Analyte V2.26 (free with spectrometer) Includes DLL libraries and SDKs for easy custom application development		

200 Micron

600 Micron

400 Micron

1000 Micron

Fiber Optic Patch Cords

UV/VIS and VIS/NIR Models for Spectrometer

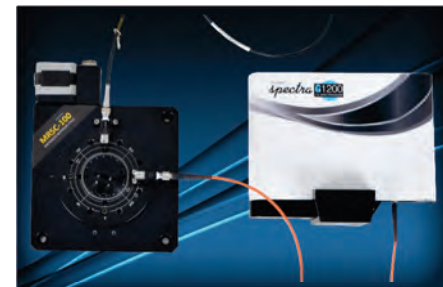

-30 Degree Cooled CCD

Peltier cooling device integrated into spectrometer sensor can reduce the temperature of the CCD chip by -30 °C against ambient, improving the dark baseline level by a significant factor of 2-3. It makes this instrument ideally suitable for measuring low light applications like fluorescence.



USB 2.0 Spectra CD 214 Spectrometer

MODELS : Spectra CD 214VIS | Spectra CD 214NIR



The Spectra Prism Spectrometer is a low-cost, lab spectrometer that is ideal for general purpose laboratory and research spectroscopic applications. The use of linear CCD array with PB prism makes it more convenient and user friendly compared to other spectrometers. It is more reliable and cost effective compared to grating spectrometers

Our CD214 Series Prism Spectrometer's wavelength range is from 400nm to 700nm and utilizes a detector with 3648 active pixels; that is 3648 data points in one full spectrum. The spectrometer is configured with a micrometer controlled entrance slit which opens from 0-3 mm in width by micrometer adjustment. Optical resolution is approximately 0.15 nm.

Spectra CD214 is a CCD based prism spectrometer. It is identical to a grating instrument except that the dispersion element used is pellen broca prism. The prism has constant efficiency over its range of transmittance. Filter is not required for measurement .In many cases, it is the ideal choice for absorption and emission spectra measurement and characterization.

CD214 Series spectrometers are available from Holmarc in various resolution and wavelength range for multitudes of spectroscopic applications. Various accessories include directly attachable light sources and sample holders. Sample holder for 10mm cuvettes connects to the entrance slit of the spectrometer. The optional dual entrance and exit ports allow the user to set up two or more experiments simultaneously. The spectrometer is flexible in design so that it can be easily customized to suit specific applications.

Specifications

Design	: Constant Deviation Spectrometer
Optical Height	: 77mm
Prism type	: Pellin Broca
Abbe number V_d	: 29.62
Slit width	: Continuously variable 0-3mm, 10 Micron Resolution Micrometer
CCD Sensor	: B/W line Sensor
Number of Pixels	: 3648
Pixel Size	: 8x200 micron
Pixel Output Clock	: 0.5 MHz
ADC resolution	: 16 bits
Exposure Time Range	: 0.1ms - 6,500ms
Frame Rate	: Up to 138 scans/second
Interface	: USB 2.0
Dimensions (LxWxH)	: 450x225x124mm

Model	Dispersion Element	Wavelength Range	Detector	Resolution
Spectra CD 214VIS	PB N-SF1	400-700nm	Line CCD 3648pixels	0.15nm
Spectra CD 214NIR	PB N-SF1	650-950nm	Line CCD 3648pixels	0.26nm

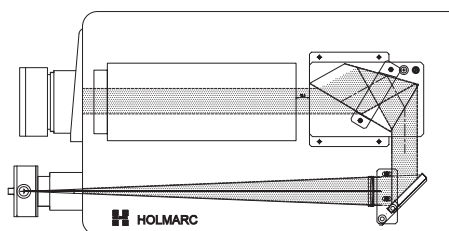
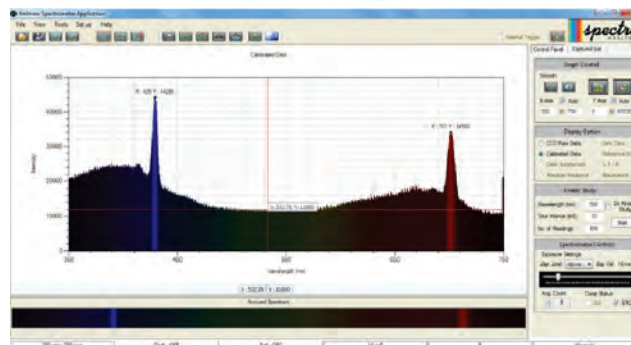

Fig. Optical Layout of Spectra CD Spectrometer.



For the spectra prism spectrometers, directly attachable light source and sample holders are available as accessories (sold separately). The most common light source is quartz halogen lamp. Sample holder we stock generally is for 10mm cuvettes which connects to the front side of the spectrometer. Software has capabilities for capturing single or continuous spectra, custom wavelength calibration, dark subtraction and intensity comparison, simultaneous display of overlay multiple spectra, exporting data to microsoft® excel etc. The software has facilities for spectrum saving in programmed intervals.

FIBER COUPLED

UV-VIS-NIR Scanning Spectrometer

MODEL : HO-SP-S100SA | HO-SP-S100MA



MODEL : HO-SP-S100MA

Designed for **Low light** spectroscopic application



SPECIFICATIONS

Optical path configuration	: Czerny-Turner type
Dispersion element	: Holographic grating
Grating density	: 1200 grooves/mm
Relative diffraction efficiency	: 45-65% (Visible)
Scanning Wavelength Range	: 190-1100nm
Wavelength range (Detector)	: 350-1100nm for HO-SP-S100SA : 185-900nm for HO-SP-S100MA
Resolution	: 0.1nm
Wavelength Repeatability	: ± 0.5 nm
Slit width	: 0-4mm (Micrometer Controlled)
Detector	: Si photodiode or PMT
Interface	: USB 2.0 or RS-232
Data formats	: Spreadsheet

Dual exit port configured model is also available. It enables simultaneous use of more than one detector. It helps to work with different wavelength regions. The software allows data retrieval from each detector independently. This can be completely automated and PC-controlled.

Fiber Optic Collimators

Multi elemental aberrations corrected design

- Fiber optic collimator
- Laser to fiber coupling
- Slit to fiber coupling
- Fiber to detector coupling

Fixed collimators for custom beam sizes can be manufactured at holmarc. Please contact our engineers at sales@holmarc.com for your special requirements.

Features:

- ▶ Fiber Coupled Input Slit
- ▶ High resolution spectral analysis
- ▶ High wavelength accuracy
- ▶ 190 - 1100nm spectral range in a single scan
- ▶ Photomultiplier and silicon photo detector Options
- ▶ Adjustable Input and output slit to control the spectral resolution
- ▶ Adjustable wavelength steps
- ▶ RS-232 and USB to serial port extension module



Scanning spectrometer is specially designed and developed for industrial and academic research laboratories in the fields of biology, chemistry, physics, environmental science and engineering. This device works in the wavelength range of 190 to 1100nm. Scanning spectrometer can rapidly scan a range of wavelengths and record light intensity at each wavelength.

Input and output ports of the spectrometer are fitted with precise micrometer controlled variable slits. A plane holographic grating is used to diffract the input light that is subsequently focused by a second concave mirror. The holographic gratings used in the instrument minimize stray light for high sensitivity and accuracy. A stepper-motor controlled sine drive positions the grating, which is mounted on a precision rotary table. The sine drive delivers a linear relationship between stepper motor motion and wavelength of interest. It includes a mechanism to change the wavelength selected by the software and to record the resulting changes in the measured quantity as a function of the wavelength.

The software developed for the instrument has facilities for setting up and calibration in addition to scanning and manual readout. Scanning is possible for a desired wavelength range too. This feature saves time whenever full wavelength range scan is not necessary. The software stores and displays the data acquired on MS Excel sheet. This helps to plot graph with ease whenever required.



MODEL : HO-SP-S100SA

Designed for **general** spectroscopic application

Heavy duty aluminium construction is used for stability with respect to vibration and thermal effects. Multiple accessory options allow the user to configure the system for custom applications. The basic system and accessories are designed in modular fashion. More and more accessories can be added as the applications expand.

There are two types of single channel detectors for using with scanning spectrometers, photomultiplier tube (Model : HO-SP-S100MA) and silicon photo diode (Model : HO-SP-S100SA). For general emission and absorption experiments, scanning spectrometer with silicon photo diode is suitable. It can be used for spectroscopic study of LED and other optical filters. PMT detectors typically offer much high sensitivity to low light levels than silicon photo diode and are suitable for Raman spectrum, fluorescence, bioluminescence and chemiluminescence.

Spectra CT UV-VIS-NIR CCD Based Stitched Scanning Spectrometer

MODEL : HO-SP-3S300F

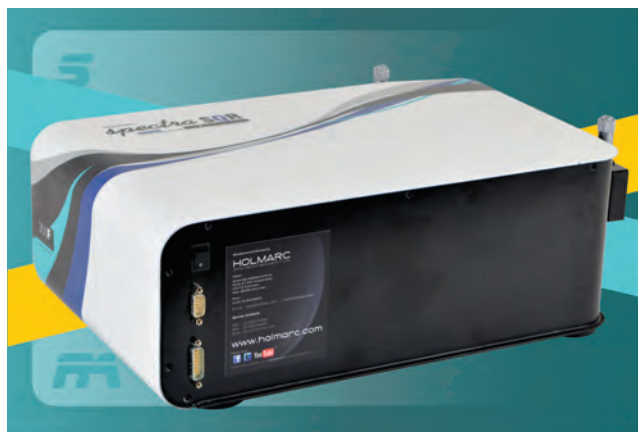

Features:

- ▶ High resolution spectral analysis
- ▶ High wavelength accuracy
- ▶ 200 - 1100nm spectral range in a single scan
- ▶ Optional photomultiplier and silicon photo diode detector
- ▶ Adjustable Input slit to control the spectral resolution
- ▶ Selectable wavelength range
- ▶ RS-232 and USB to serial port extension module
- ▶ Optional optical port with optical output and detector input ports

Scanning is possible for a desired wavelength range. This feature saves time whenever full wavelength range scan is not necessary. Electronics is packaged inside the housing and has RS-232 interface to the computer. For USB interface a Serial to USB converter is connected to the RS-232 output and a USB converter driver needs to be loaded on the computer so that it will recognize the USB interface as a virtual RS-232 serial port. There is also a fast and interactive graphical software interface allowing full control of all the spectrograph functions.

Heavy duty aluminium construction is used for stability with respect to vibration and thermal effects. Multiple accessory options allow the user to configure the system for custom applications. The basic system and accessories are designed in modular fashion. More and more accessories can be added as the applications expand.

It can be used for spectroscopic study of LED's, optical filters, general emission and absorption experiments etc.

Dual exit port configured model is also available. It enables simultaneous mounting of different detectors. It helps to work with different wavelength region. The Software allows usage of all the functions of each device independently. All systems can be made completely automated and PC-controlled.

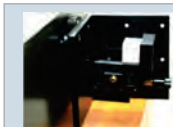

Detector Stages for Spectrometer

Holmarc manufacture custom detector mounts and stages for your application. Please contact us with your custom requirement at sales@holmarc.com,



HOLMARC's Model HO-SP-3S300F is a CCD based scanning spectrometer, rapidly scan a range of wavelengths and record light intensity at each wavelength. In this spectrometer, only 70nm wavelength range is covered in a single imaging, by making use of the entire 3648 pixels available in the CCD. This feature increases the resolution significantly. For obtaining spectra over full wavelength range, various spectral images are taken and stitched together using the software provided. Hence this device is named "Stitched Scanning Spectrometer". It works in the wavelength range of 200 to 1050nm.

Holographic diffraction grating used in this spectrometer disperses light by diffracting different wavelengths at different angles and it is subsequently focused by a second concave mirror. The grating is positioned in such a way to get all the wavelength of light in to a linear CCD. The required wavelength range is selected by rotating angle of the grating. The mirror and slit positions remain fixed. It utilizes a computer controlled motorized turret for automatic grating and wavelength selection. Resolution and wavelength range of the spectrometer depends on the selection of grating.

Specifications

Optical path configuration	: Czerny-Turner type
Focal Length	: 300mm
Aperture Ratio	: f/6
Port Configuration	: Single I/P & O/P (Customizable)
Dispersion element	: Holographic grating UV Optimized
Grating density	: 1200
Grating Size	: 50x50mm
Relative diffraction efficiency	: 65 %
Wavelength range	: 200-1100nm
Resolution with CCD (FWHM)	: ~ 0.058nm
Band width per pixel	: ~ 0.029nm
Slit width	: 0-3mm, Micrometer controlled
Slit Resolution	: 10 Micron
Dispersion	: 2.459 nm/mm @ 350nm
CCD wavelength coverage	: 70nm
CCD Sensor	: B/W line Sensor
Number of Pixels	: 3648
Pixel Size	: 8x200 micron
Pixel Output Clock	: 0.5 MHz
ADC resolution	: 16 bits
Exposure Time Range	: 0.1ms - 6,500ms
Frame Rate	: Up to 138 scans/second
interface	: USB2.0
Compatibility	: Windows 2000XP or higher

Default slit width is 20 μ m
Spectral Coverage: approximate, use for reference purpose only



Spectra CT UV-VIS-NIR CCD Based Multi Channel Scanning Spectrometer

MODEL : HO-SP-3S300FS

Sony ICX413AQ CCD Based



HOLMARC's Model HO-SP-3S300FS is a CCD based scanning spectrometer designed for multichannel spectroscopic application, can hold up to 10 No.s of 600 micron optical fibers at the input slit (Optional- Can be customized as per requirements). It can rapidly scan a range of wavelengths and record light intensity of all the channels at each wavelength. In this spectrometer, only 58nm wavelength range is covered in a single imaging, by making use of the entire 3032x2016 pixels available in the CCD. This feature increases the resolution significantly. For obtaining spectra over full wavelength range, various spectral images are taken and stitched together using the software provided. Hence this device is named "Stitched Scanning Spectrometer". It works in the wavelength range of 340 to 1050nm.



Holographic diffraction grating used in this spectrometer disperses light by diffracting different wavelengths at different angles and it is subsequently focused by a second concave mirror. The grating is positioned in such a way to get all the wavelength of light in to a linear CCD. The required wavelength range is selected by rotating angle of the grating. The mirror and slit positions remain fixed. It utilizes a computer controlled motorized turret for automatic grating and wavelength selection. Resolution and wavelength range of the spectrometer is depends on the selection of grating.

Features:

- ▶ Trigger In & Trigger Out function
- ▶ High resolution spectral analysis
- ▶ High wavelength accuracy
- ▶ 340 - 1050nm spectral range in a single scan
- ▶ Optional photomultiplier and silicon photo diode detector Attachment
- ▶ Adjustable Input slit to control the spectral resolution
- ▶ Selectable wavelength range
- ▶ RS-232 and USB to serial port extension module
- ▶ Optional optical port with optical output and detector input ports

Electronics is packaged inside the housing and has RS-232 interface to the computer. For USB interface a Serial to USB converter is connected to the RS-232 output and a USB converter driver needs to be loaded on the computer so that it will recognize the USB interface as a virtual RS-232 serial port. There is also a fast and interactive graphical software interface allowing full control of all the spectrograph functions.

Heavy duty aluminium construction is used for stability with respect to vibration and thermal effects. Multiple accessory options allow the user to configure the system for custom applications. The basic system and accessories are designed in modular fashion. More and more accessories can be added as the applications expand.

It can be used for spectroscopic study of LED's, optical filters, general emission and absorption experiments etc.

Dual exit port configured model is also available. It enables simultaneous mounting of different detectors. It helps to work with different wavelength region. The Software allows usage of all the functions of each device independently. All systems can be made completely automated and PC-controlled.

Specifications

Optical path configuration	: Czerny-Turner type
Focal Length	: 300mm
Aperture Ratio	: f/6
Port Configuration	: Single I/P & O/P (Customizable)
Dispersion element	: Holographic grating UV Optimized
Grating density	: 1200
Grating Size	: 50x50mm
Relative diffraction efficiency	: 65 %
Wavelength range	: 340-1050nm
Resolution with CCD (FWHM)	: ~ 0.058nm
Band width per pixel	: ~ 0.029nm
Slit width	: 0-3mm, Micrometer driven
Slit Resolution	: 10 Micron
Dispersion	: 2.3 nm/mm @ 532nm
CCD wavelength coverage	: 58nm
interface	: USB2.0

CCD detector Specifications

Sensor	: Sony ICX413AQ Color
Sensor size	: 1.8" (25.10mm x 17.64mm)
Pixel size	: 6.45x6.45 Micron
Effective pixels	: 3032 x 2016
CCD scan mode	: Interline
Maximum fps	: 2.5fps(3020 x 2016), 10fps (720 x 400) ROI mode
A/D conversion	: 12 bit (16-bit application data)
Peltier cooled	: -30°C below ambient
Exposure time	: 0.1ms-60minute
Gain	: 6.88 dB in hardware, up to 100% sensitivity boost
Overall System Gain	: 8.5135 e/ADU
Readout Noise	: 5.7 e
Maximum Level	: 4095.0 ADU
Full Well Capacity	: 34863 e (minimum)
Dynamic Range	: 75.8 dB
Signal to Noise Ratio	: 45.4 dB
Data interface	: USB2.0/480Mb/s

Spectra **UV-VIS-NIR** Standard Monochromators

Model : HO-SP-M01S & Model : HO-SP-M03S



Features

- ▶ Micrometer adjustable slits to precisely control incoming light.
- ▶ User specified gratings to meet specific applications
- ▶ Stepper motor scanning for precision wavelength positioning
- ▶ Internal shutter or filter wheel(Optional)
- ▶ Motorized slit (Optional)
- ▶ Custom configurations

Monochromator consists of diffraction grating, slits and spherical mirrors, all held by precision opto-mechanical mounts. The input light source, which is always application dependent, typically emits a broad spectrum of radiations. Diffraction grating disperses light by diffracting different wavelengths at different angles. The angular position of the grating is adjusted by the use of rotary stage so that light with required wavelength is passed through the exit slit and all other wavelengths are blocked, without changing position of mirrors and slits.

Precision stepper motor controlled rotation stage is used for driving the grating. Very fine resolution for the grating stage is achieved by the micro-stepping feature of the stepper motor control. Wavelength selection is made much easier in automated system compared to manually adjusted versions.

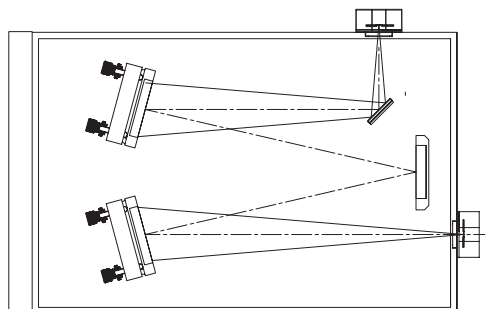

Fig. Optical Layout of Spectra HO-SP-M01S Monochromator

Other model in standard series monochromator

Model : HO-SP-M02S >>> 400mm Focal length Monochromator

Model : HO-SP-M04S >>> 600mm Focal length Monochromator



HOLMARC's Spectra UV-VIS-NIR standard monochromators are designed for general spectroscopic research needs. These monochromators are designed using single 1200lines/mm holographic precision grating. A microprocessor onboard controls the motor for precision wavelength positioning. The instrument can be operated either from the front panel or through a personal computer which can be interfaced with the device by using RS 232C serial port. The front panel of the device has user friendly keyboards and back lit LCDs. Input and output ports of the monochromator are fitted with precise, micrometer controlled variable slits. Mirrors are kinematically mounted for fine tuning during installation and setup. The software developed for the instrument has facilities for setting up and calibration as well. System accepts input data as wavelength or wave number.

SPECIFICATIONS

Model : HO-SP-M01S

Optical path	: Czerny-Turner Configuration
Wavelength Range	: 200 -1600nm
Scanning Range	: 200-1100nm(Default)
Collimating & Focusing mirror	: 50mm dia, 300F
Optical Grating	: 1200 l/mm
Grating Size	: 50X50mm
Absolute Diffraction Efficiency	: 45 - 65%
Slit Width	: 0~3mm Continuously Adjustable
Resolution	: 0.1nm (@ 546nm, 10µm slit width)
Wavelength Accuracy	: ≤ 0.2nm
Wavelength Repeatability	: ≤ 0.1nm
Stray Light	: ≤ 10 ⁻³
Reciprocal of Linear Dispersion	: 2.7mm
Half-Width of Spectral line	: ≤ 0.2nm @ 586nm

SPECIFICATIONS

Model : HO-SP-M03S

Optical path	: Czerny-Turner type.
Focusing mirror	: 80mm dia, 500F,
Collimating mirror	: 80mm dia 500F,
Clear aperture	: 76.92mm
Coating	: Broadband Al-Coating
Folding mirror	: 55X40mm
Grating Size	: 50x50mm (68x68mm Optional)
Resolution	: 0.05nm @ 435.8nm [1200gr/mm grating, 10µm slits]
Accuracy	: +/- 0.2nm
Repeatability	: +/- 0.04nm
Drive-step size	: 0.0025nm with 1200gr/mm
Dispersion	: 1.7nm/mm
Aperture	: f/6.5
Interface	: RS232 & USB Standard
Focal-plane size	: 26mm wide x 14mm high

- A fixed diverter mirror assembly for entrance side port
- A exit selection diverter mirror assembly for exit ports
- A micrometer controlled adjustable slit for entrance and exit ports, 0 to 3mm(10micrometer increment/decrement unit)

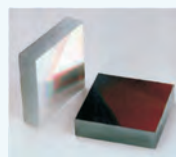

Available Holographic Grating Options

- 1200 l/mm
- 1800 l/mm
- 2400 l/mm

Monochromators are available in various port configurations.
Single I/P & O/P port, Double I/P & O/P port
Single I/P & Double O/P port, Double I/P & Single O/P port



Mini Monochromator Compact, Automated Scan

HO-SP-150F6 Series

HOLMARC's New 125mm & 150mm focal length CT monochromators are compact mini optical system delivering a high performance, reliable solution wide scan wavelength measurement over UV-VIS-IR region (185nm-3300nm). Its features are comparable to many larger, more expensive, conventional models. At just 16x8cm the 125F5 monochromator (20x10cm for 150mmF6 monochromator) features a compact design with a single entrance and exit slit with up to two diffraction gratings ideal for accommodation into the smallest of spaces available, particularly suitable in OEM applications.

The 150F6 monochromator is ideally suited to measurements whereby a medium to lower spectral resolution is required, i.e. as tuneable light source, wavelength scan measurement system etc. Suitable for integration into a larger measurement system. Because of the compact design it can be used in a variety of sophisticated analytical and biomedical equipment such as: clinical chemistry analyzers, HPLC detectors, and UV-VIS-NIR spectrophotometers.

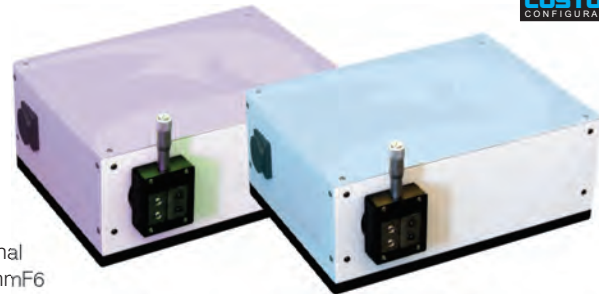

General Specifications

Optical Layout : Czerny Turner
Focal length : 120, 125 & 150mm
Grating mount : Single/Dual grating turret
Number of gratings : 1-2
Grating size : 25 x 25mm
Aperture ratio : f/4, f/5 & f/6
Number of entrance/ exit ports : 1
Fiber optic coupler plate : Yes,
converts slit aperture to SMA connector
Mechanical resolution drive : 0.000072°/ step
Slit type : Fixed, Micrometer or motorized
Slit width : 10µm-2mm
Slit height : 12mm
Higher order filter size : 12.5mm
Linear dispersion : 3.9nm/mm (150mm f)
Wavelength accuracy : ± 0.25nm
Resolution @ 25µm Slit width &
1200/mm Configuration : 0.098nm
Computer interface : USB 2.0
Software control : Holmarc Spectra Scan

Model	Wavelength Range	f #	Grating	Resolution Typical Operation
HO-SP-120F4-M1	350-1100nm	f4	Single, 1200l/mm	1.25nm
HO-SP-125F5-M1A	190-1100nm	f5	Single, 800l/mm	1.75nm
HO-SP-125F5-M1B	190-900nm	f5	Single, 1200l/mm	1.2nm
HO-SP-125F5-M1C	350-700nm	f5	Single, 2400l/mm	0.65nm
HO-SP-150F6-M1A	190-1100nm	f6	Single, 800l/mm	1.5nm
HO-SP-150F6-M1B	190-900nm	f6	Single, 1200l/mm	1nm
HO-SP-150F6-M1C	350-700nm	f6	Single, 2400l/mm	0.5nm
HO-SP-150F6-M2A	190-1100nm	f6	Dual, 1200 & 2400 l/mm	0.5nm
HO-SP-150F6-M2B	190-1600nm	f6	Dual, 800 & 1200 l/mm	1nm
HO-SP-150F6-M2C	1000-3300nm	f6	Dual, 800 & 600 l/mm	1.5nm

Mini Monochromators Feature

- Can be held in any position vertical or horizontal
- Provision to screw a rectangular to round fibre patch cord on both input and output slit
- Computer control of monochromator with QSR software (Lab View support)



Manual Mini Monochromator 125mm F5 & 100mm F4 - Handheld Size

HO-SP-125F5 & HO-SP-100F4 Series

HOLMARC's MMS-125F5 hand held Mini Monochromator is a manually operated light weight monochromator size of that utilizes a knob dial and a precision linear engraved top for wavelength selection. For quick wavelength selection a quick release lever also provided. Precision lead screw sine bar mechanism is used for the rotation of the diffraction grating which positions the selected wavelength at the exit slit. Wavelength can be read directly in nanometers from engraved top.

These are ideal choice for compact wavelength selection system. 0-5 mm micrometer controlled variable slit is used for the wavelength band width controls. Narrower slits increase resolution but decrease throughput. Wider slits increase throughput at the expense of spectral purity.

Note: It is possible to converts slit aperture to SMA connector.

Model	Wavelength Range	f #	Grating	Resolution Typical Operation
HO-SP-125F5-M1A	190-1100nm	f5	Single, 800l/mm	1.75nm
HO-SP-125F5-M1B	190-900nm	f5	Single, 1200l/mm	1.2nm
HO-SP-125F5-M1C	350-700nm	f5	Single, 2400l/mm	0.75nm
HO-SP-100F4-M2A	190-1100nm	f4	Single, 800l/mm	2nm
HO-SP-100F4-M2B	190-900nm	f4	Single, 1200l/mm	1.5nm
HO-SP-100F4-M2C	350-700nm	f4	Single, 2400l/mm	1nm



General Specifications

Optical Layout : Czerny Turner
Focal length : 125mm & 100mm
Grating mount : Single
Grating size : 25 x 25mm
Aperture ratio : f/5 & f/4
Number of entrance/ exit ports : 1
Fiber optic coupler plate : Yes,
Converts slit aperture to SMA connector
Mechanical resolution drive : 0.000072°/ step
Slit type : Fixed
Slit width : 10µm-3mm
Slit height : 12mm
Higher order selection : Manual
Higher order filter size : 12.5mm

Spectra **UV-VIS-NIR** Quasar Series Scientific Monochromators

MODEL : HO-SP-SQR500FA | HO-SP-SQR300FA | HO-SP-SQR500F | HO-SP-SQR300F



HOLMARC's Spectra Quasar Series Monochromators **Model : HO-SP-SQR500FA & HO-SP-SQR300FA** are fully automated, triple grating instruments with dual output port while **Models HO-SP-SQR500F and HO-SP-SQR300F** are single grating instruments with single output port. All the four models are designed for fast, automated and continuous scanning over broad spectral range. The angular position of the grating is adjusted by the use of sine drive mechanism so that only the required wavelength of light is passed through the exit slit and all other wavelengths are blocked, without changing the positions of mirrors and slits.

Spectra Quasar series monochromators are ideal choice for either single or multichannel detector to be used in many applications that require medium to high spectroscopic resolution with excellent stray light performance such as fluorescence, Raman, absorption and transmission. Spectra series monochromators are fully automated with microprocessor controls and can be interfaced with the device by using RS 232C serial port. Input and output ports of the monochromator are fitted with precise, micrometer controlled variable slits. The software developed for the instrument has facilities for setting up and calibration as well. System accepts input data as wavelength or wave number. Various configurations of input and output ports are available with precision and long life time.

Features

- ▶ Can be used as stitched or continuous scanning spectrometer.
- ▶ Micrometer adjustable slits to precisely control incoming light.
- ▶ User specified gratings to meet specific applications
- ▶ Stepper motor scanning for precision wavelength positioning
- ▶ Internal shutter or filter wheel (Optional)
- ▶ motorized slit (Optional)
- ▶ Custom configurations



Detector Stages for Monochromators

Holmarc manufactures custom detector mounts and stages for your application. Please contact us with your custom requirements at sales@holmarc.com, mail@holmarc.com

Precision stepper motor controlled rotation stage is used for driving the grating. Fine resolution for the grating stage is achieved by micro-stepping feature of the stepper motor drives. Wavelength selection is made much easier in automated system compared to manually adjusted versions.

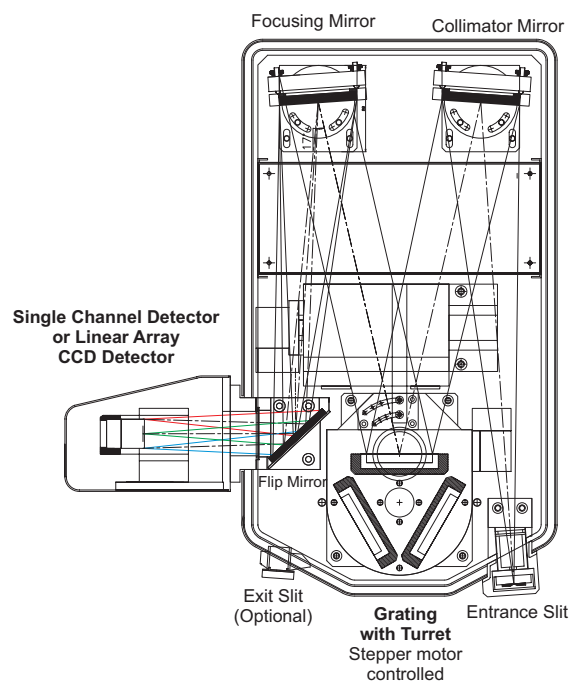

Spectra Light Sources



HOLMARC offers a number of light sources to cover the spectral range of 200 - 2000nm which can be mounted directly to our monochromators or can be used independently. With the appropriate adapters, some of the sources can be mounted to our monochromators along with an optical chopper or filter wheel. Additional adapters and interface kits are available for focusing and launching the light directly into optical fibers.

Spectra Quasar 500FA Monochromator

SPECIFICATIONS

Model : HO-SP-SQR500FA

Spectra Quasar 500F Fully Automated Monochromator
Optical Design : Czerny-Turner
Input Port : Dual
Output Port : Dual (One for Monochromatic Light and other for single / multi channel spectral application)
Port Selection Mechanism : Integrated Motorized Flip Mirror based Mechanism
Main Mirrors : Parabolic type with Enhanced Aluminum Coating
Focal Length : 500mm
Diameter : 68mm or 120mm
Aperture Ratio : f/5 (with 100x100mm grating) or f/7.3 (with 68x68mm grating)
Dispersion Element : Holographic Grating

Grating Size : 100x100mm (Ruled Grating) Custom grating can be provided on request)

Grating Density : 1200 l/mm
Wavelength Range : 200-1600nm
Diffraction Efficiency @532nm : 65%
Dispersion : 1.426 nm/mm
Resolution : 0.029nm
Mechanical Wavelength Range @1200 l/mm : 200-1600nm
Accuracy : 0.01 nm (with 1200-g/mm grating)
Reproducibility : ±0.005 nm (with 1200-g/mm grating)
Grating Mounting Design : Triple Grating Turret Based (Can hold up to 3 Gratings)
Mount Design : Kinematic Top Adjustable Mounts
Grating Rotation : Front Surface Axis
Output Port Size : 30mm
Focal Imaging Plane : 30x12mm
Focal Plane Extension from the port : 42mm
Scanning Speed : 160nm/second
Step Size Resolution : 0.001nm
Input and Output Slit Design: Integrated Motorized Slit or Manual Slit
Slit Width Range : 0-3mm
Resolution : 1Micron
Shutter : Integrated motorized Active Shutter
Filter unit : Higher order cut off filter wheel
Calibration : Auto calibration for all motorized function (Manual Calibration can be activated for wavelength calibration)
Software : Windows based software to control all spectrometer functions and detector readings (with Labview interface support)

Spectra Quasar 500F Monochromator

SPECIFICATIONS

Model : HO-SP-SQR500F

Optical Design : Czerny-Turner
Input Port : Single
Output Port : Dual (One for Monochromatic Light and other for single / multi channel spectral application)
Main Mirrors : Parabolic type with Enhanced Aluminum Coating
Focal Length : 500mm
Aperture Ratio : f/10 (with 50x50mm grating)
Dispersion Element : Holographic Grating
Grating Density : 1200 l/mm
Wavelength Range : 200-1100nm
Diffraction Efficiency @532nm : 65%
Dispersion : 1.426 nm/mm
Resolution : 0.029nm
Mechanical Wavelength Range @1200 l/mm : 200-1600nm
Accuracy : 0.01 nm (with 1200-g/mm grating)
Reproducibility : ±0.005 nm (with 1200-g/mm grating)
Grating Mounting Design : Single Grating
Grating Rotation : Front Surface Axis
Grating Holding Sizes : 50x50mm, 68x68mm (Grating adaptor will be provided)
Grating Removal Port : Yes
Output Port Size : 30mm
Focal Imaging Plane : 30x12mm
Focal Plane Extension from the port : 42mm
Slit Width Range : 0-3mm (Manual)
Resolution : 1Micron
Filter unit : Higher order cut off filter wheel
Software : Windows based software to control all spectrometer functions and detector readings (with Labview interface support)

Spectra Quasar 300FA Monochromator

SPECIFICATIONS

Model : HO-SP-SQR300FA

Spectra Quasar 300F Fully Automated Monochromator
Optical Design : Czerny-Turner
Input Port : Single
Output Port : Dual (One for Monochromatic Light and other for single / multi channel spectral application)
Port Selection Mechanism : Integrated Flip Mirror based Mechanism
Main Mirrors : Parabolic type with Enhanced Aluminum Coating
Focal Length : 300mm
Collimating Mirror Size : 50x50mm
Focusing Mirror Size : 75x50mm
Aperture Ratio : f/6 (with 50x50mm grating)
Dispersion Element : Holographic Diffraction
Grating Size : 50x50mm
Grating Density : 1200 l/mm and 600 l/mm
Wavelength Range : 200-2000nm
Diffraction Efficiency @532nm : 65%
Dispersion : 2.29 nm/mm (52.13 cm-1/mm)
Resolution : 0.046nm
Mechanical Wavelength Range @1200 l/mm : 200-2000nm
Accuracy : 0.05 nm (with 1200-g/mm grating)
Reproducibility : ±0.01 nm (with 1200-g/mm grating)

Grating Mounting Design : Dual Grating Turret Based
Mount Design : Kinematic
Grating Rotation : Front Surface Axis
Focal Imaging Plane : 30x12mm
Focal Plane Extension from the port : 20mm
Scanning Speed : 160nm/second
Step Size Resolution : 0.001nm
Input and Output Slit Design: Integrated Motorized Slit or Manual Slit
Slit Width Range : 0-3mm
Resolution : 1Micron
Shutter : Integrated motorized Active Shutter
Filter unit : Higher order cut off filter wheel

Calibration : Auto calibration for all motorized function (Manual Calibration can be activated for wavelength calibration)
Software : Windows based software to control all spectrometer functions and detector readings (with Labview interface support)

Spectra Quasar 300F Monochromator

SPECIFICATIONS

Model : HO-SP-SQR300F

Optical Design : Czerny-Turner
Input Port : Single
Output Port : Dual (One for Monochromatic Light and other for single / multi channel spectral application)
Main Mirrors : Parabolic type with Enhanced Aluminum Coating
Focal Length : 300mm
Collimating Mirror Size : 50x50mm
Focusing Mirror Size : 75x50mm
Aperture Ratio : f/6 (with 50x50mm grating)
Dispersion Element : Holographic Grating
Grating Size : 50x50mm
Grating Density : 1200 l/mm
Wavelength Range : 200-1100nm
Diffraction Efficiency @532nm : 65%
Dispersion : 2.29 nm/mm (52.13 cm-1/mm)
Resolution : 0.046nm
Mechanical Wavelength Range @1200 l/mm : 200-1600nm
Accuracy : 0.1 nm (with 1200-g/mm grating)
Reproducibility : ±0.05 nm (with 1200-g/mm grating)
Grating Mounting Design : Single Grating
Grating Rotation : Front Surface Axis
Grating Removal Port : Yes
Output Port Size : 30mm
Focal Imaging Plane : 20x12mm
Focal Plane Extension from the port : 50mm
Slit Width Range : 0-3mm (Manual)
Resolution : 1Micron
Filter unit : Higher order cut off filter wheel
Software : Windows based software to control all spectrometer functions and detector readings (with Labview interface support)

Spectra **UV-VIS-NIR** High Throughput DUAL Grating f/3.5 Monochromator

MODEL : HO-HTDG 175F2



HOLMARC's 175F2 monochromator having 175 mm focal length is an out-of-plane version of Ebert-Fastie monochromator. It is designed with large optics for high light throughput and f/3.5 aperture, optimized to provide excellent stray light rejection while minimizing aberrations. The optical configuration is designed to ensure high resolution and maximum throughput.

175F2 has computer controlled, motorized turret for automatic grating and wavelength selection. It offers 0.2nm resolution in UV-VIS region with 1200 lines/mm grating and 0.25nm in IR region with 600 lines/mm ruled grating, covering wavelength range of 250nm to 1900nm. Monochromator includes adjustable micrometer controlled input and output slit.

Hand Controller

175F2 includes a connector to utilize the optional Handheld Controller for manual operation without using computer. There is no need to memorize commands or key sequences. The backlit LCD display provides information on the selection of grating, active filter, current wavelength etc



Fig : 175F2 f/3.5 Monochromator with 150W Xenon Arc Lamp/ Hand held controller and fiber optic coupled slit

Specifications

Focal Length : 175mm
Focal ratio F/# : F/3.5
Wavelength Selection Method : Motorized Sine Drive
Grating : Holographic 1200l/mm and 600l/mm ruled precision gratings
Wavelength Range : 250-1900nm
Grating Size : 50x50mm
Grating Turret : Yes, Two grating turret with grating
Wavelength Accuracy : 0.2 nm with 1200 l/mm grating
Wavelength Precision : 0.1 nm
Stray Light : 0.03%
Number of ports : 1 input port and 1 output port
Slit : Variable Micrometer Slit
Resolution : 10 Micron
Slit opening : 0-3mm
Higher order cut off filter : Yes – Motorized filter wheel unit
Interface : USB 2.0
Handheld control unit : Optional
Software : Spectra SQR

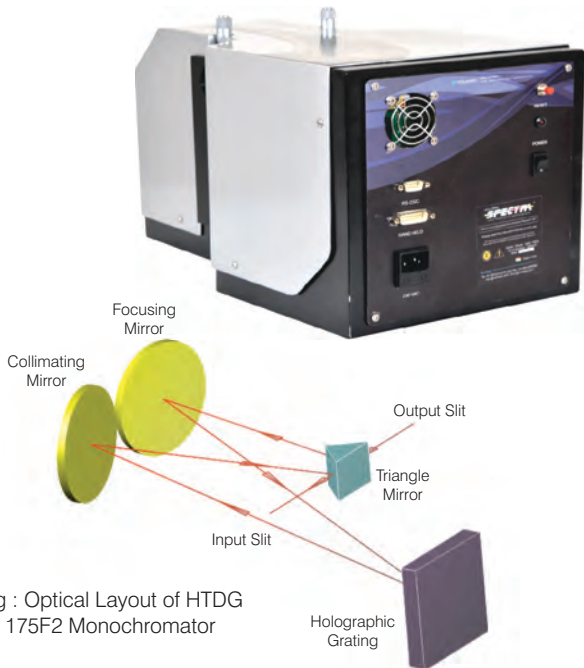
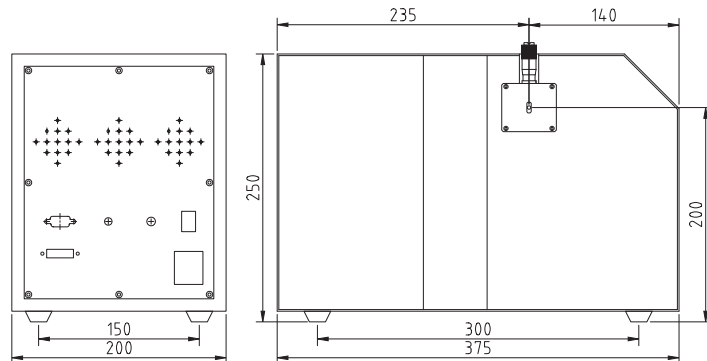

Fig : Optical Layout of HTDG 175F2 Monochromator

Customization:

HOLMARC has built reputation for providing custom solutions. Whether you need a small modification to the existing system or a completely novel design, built from scratch up to meet your technical specifications, HOLMARC's engineering and optical design groups are ready to help.



LASER Raman Spectrometer (PMT Based)

Model : HO-SP-LRS217



Holmarc's Laser Raman Spectrometer (Model : HO-SP-LRS217) is a useful instrument for the identification of wide range of substances in physics and chemistry laboratories. The procedure followed in this equipment is illuminating a sample with DPSS green laser and using a monochromator to examine the light scattered by the sample. It is a straight forward, non destructive technique requiring no sample preparation.

This spectrometer is designed for recording raman emissions from solids as well as liquids when a laser beam is passed through the sample. The apparatus suits Chemistry as well as Physics labs for characterizing materials by recording raman emissions. The set up consists of 40mW DPSS laser (532 nm), collection optics, sample mount, stages, monochromator and detector.

The monochromator is PC controlled and motorized. The experiment is conducted by scanning the emission spectrum by monochromator and recording the intensity of each interested wavelength from the detector. The readings are plotted on a graph. Monochromator used in the system has high resolution and low stray light.

When a light beam emitted by the laser device passes through an external optic path and irradiates the sample, the scattered light enters the monochromator. When the grating in the monochromator is rotated, light signal passes through a slit and falls on a highly sensitive detector (PMT). The detector output is sent to the computer for further processing.

Features :

- ▶ Computer-controlled, user-friendly interface.
- ▶ Capable of automatic recording of Raman spectra.
- ▶ DPSS laser is used as light source.
- ▶ Both solid and liquid samples can be analyzed.
- ▶ The system is assembled as a standalone unit with a footprint of 800 x 600mm.
- ▶ High sensitive PMT is used as detector.
- ▶ PMT protection circuit.
- ▶ Both manual and automatic recording of data possible.

Specifications :

Laser source : 532nm 40mW DPSS Laser
Wavelength Range : 200 ~ 800nm (Monochromator)
Wavelength Accuracy : $\leq 0.4\text{nm}$
Wavelength Repeatability : $\leq 0.2\text{nm}$
Reciprocal of Linear Dispersion : 2.7mm
Half-Width of Spectral line : $\leq 0.2\text{nm @ } 586\text{nm}$

Monochromator

Relative Aperture Ratio : D/F 1/5.5
Optical Grating : 1200 /mm
Slit Width : 0 ~ 2mm Continuously Adjustable



Detector

PMT is used as detector. It is placed near exit slit in a closed enclosure. The high voltage power supply required for PMT is integrated with detector housing.

Control Electronics and Software

Electronics hardware is integrated with monochromator, detector and laser source, so that fully automatic operation is possible from interfaced computer. Software developed is dedicated for Laser Raman spectrometer with all standard capabilities. Holmarc's engineers entertain customization of this software on request.

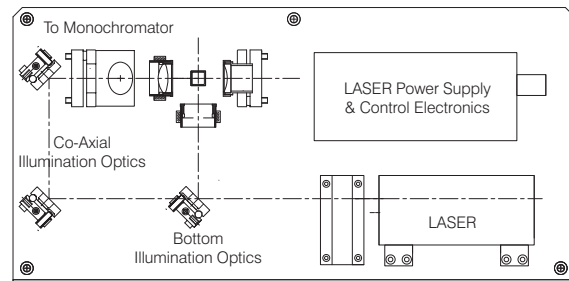

CCD Based LASER Raman Spectrometer (Compact Model)

Model : HO-SP-LRS218



Raman an extremely useful and powerful analytical tool. Holmarc's new CCD based spectrometers configured for Raman spectroscopy applications that can record Raman spectrum of different liquid, solid, or powder samples. Raman spectroscopy is becoming an increasingly important spectroscopic tool for analytical chemistry. Raman spectroscopy is one of the underutilized techniques in undergraduate chemical education. Cost is a primary reason. Holmarc LRS218 Raman spectrometer is a low cost solution for measuring Raman spectrum.

System include cooled CCD array detectors for 532nm Raman or 785nm Raman (other wavelengths available on request). Coupled with a laptop computer and our Spectra LRS software, a user can quickly collect a Raman spectrum.



Specifications

Spectrometer Type	: C1216
Design	: Czerny Turner
Diffraction Gratings	: 1200 g/mm
Optical Resolution	: 2 cm ⁻¹
Signal to Noise	: 500:1
Detector Type	: Cooled Line CCD
Number of pixels	: 3648 pixels
Digitizer	: 16 Bit
Integration Time	: 0.1 to 6500 ms
Power Consumption	: <100mA
Interface	: USB powered
Spectral Range @532nm	: 200-2200 cm ⁻¹
Stray Light	: <0.1%
Operating Systems	: WinXP, Vista, Win7 (32/64-bit)
Exposure Times	: 1ms to 60sec
Software	: HOLMARC Spectra LRS

INTERFERENCE Spectrometer Multiple Beam Interference Spectroscopy

Model : HO-S-MBIS-IF215HR

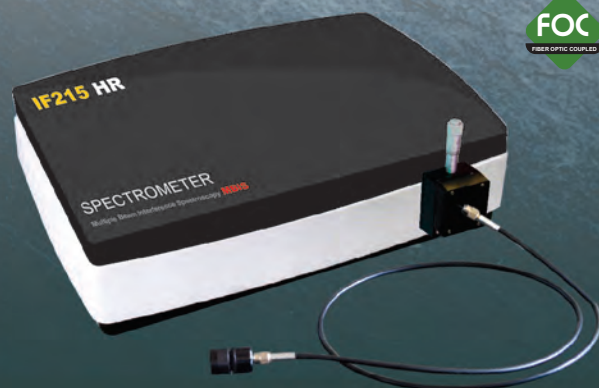

In multiple beam interference spectroscopy (MBIS) a high resolution Fabry-Perot Etalon is used to generate interference fringes over the light spectrum. These fringes are very sensitive to detect wavelength in the range of 0.001nm. HOLMARC USB 2.0 Spectra IF215HR spectrometer is used to image and record the interference spectrum in the wavelength range of 350nm to 1000nm. It can be directly connected to the PC to monitor the fringe pattern and can save desired spectrum.

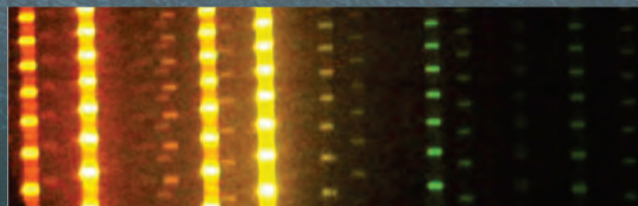

Above image shows actual interference fringes of spectrum obtained using a IF spectrometer.

LASER Raman Spectrometer

Model : HRRS 216R2

Research Grade Raman Spectrometer for quick identification of a variety of liquid, solid and powder samples



Excitation Sources
532 & 785nm

New



Raman System Features

Configurable Wavelengths

- ▶ Computer-controlled, user-friendly interface.
- ▶ Can save your samples and search for matches.
- ▶ DPSS 532nm laser source.
- ▶ Both solid and liquid samples can be analyzed.
- ▶ -30 Degree Cooled CCD Sensor for low light measurements

Holmarc's new series of updated cooled CCD spectrometers are configured for Raman spectroscopy applications, which can perform quick identification of a variety of liquid, solid or powder samples.

It has been developed to meet the needs of Material Science, Manufacturing and Biochemistry, offering high quality optical system which can be fully customized for using with fiber-optic probes. It can be used with optional microscope as well with spatial resolution down to 20 μm . Spectra software simplifies data collection and analysis. Software facilitates library searching and sample database creation.

This spectrometer is designed for recording Raman emissions from solids as well as liquids when a laser beam is passed through the sample. The apparatus suits Chemistry as well as Physics labs for characterizing materials by recording Raman emissions. The set up consists of 200mW DPSS 532nm laser with variable power controlling option, collection optics, sample mount, stages, monochromator and cooled CCD camera.

The measurements are undertaken by selective scanning method providing full spectral collection of Raman data at high spectral resolution. Spectrometer records the intensity of each interested wavelength range using cooled CCD camera. The readings are plotted on a graph. Spectrometer used in the system is having high resolution and low stray light. Electronics hardware is made integrated with spectrometer, detector and laser source, so that fully automatic operation is possible from interfaced computer.

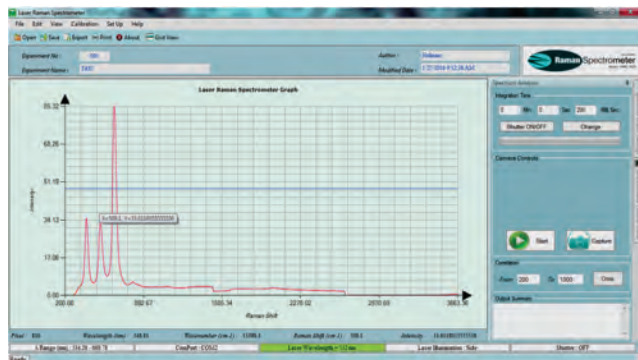

Fig. HOLMARC Spectra RA software

Optical system

Spectrometer D/f	: 1/6
Grating	: 1200L/mm
Entrance slit	: 0-2mm adjustable
Wavelength Range	: 320-1050nm (Spectrometer)
Raman Spectrum	: 200-4000 cm^{-1}
Laser Source	: DPSS 532nm low noise laser, 785nm laser (optional)
Output Power	: >200mW variable power
Wavelength Accuracy	: $\pm 0.1\text{nm}$
Wavelength Repeatability	: $\leq 0.5\text{nm}$
Resolution	: $\leq 2\text{cm}^{-1}$ at 532nm
Rayleigh Filter	: 17nm bandwidth Notch filter
CCD detector	: High sensitive CCD detector 3648 element.
Signal to noise ratio	: 500:1
A/D Resolution	: 12/16 Bit
Exposure Time	: 0.1 - 6500 ms
Optics mirrors	: Protective aluminium coated and aspherized achromatic lenses optimized for VIS-NIR range.
Objective lens	: Aspherized achromatic 0.45N.A objective lens with 10mm W.D
Sample holder	: Accommodate standard 10mm cuvette, custom sample holders
Sample positioning	: XYZ micrometer with step resolution of 10 micron.

Software

HOLMARC's Spectra RA software features all the functions required for Raman spectra acquisition and analysis. Data processing include data smoothing (Savitsky-Golay, Moving average), difference, normalization, base line correction, peak detection etc. Spectral comparison from the data base implemented in the software provides automatic detection of samples. Data can be exported in spread sheet format compatible with Microsoft Excel.

Confocal Laser RAMAN Spectrometer

Model : HO-ED-SP-CRM215



- Confocal Light collection
- High lateral spatial resolution
- Excellent depth resolution
- Large collection angle for the Raman light

Holmarc manufactures and supplies confocal laser raman spectrometer as a fully assembled and ready to use instrument for material characterization and identification in industry as well as research labs.

Holmarc's Confocal Laser Raman Spectrometer combines an inverted microscope having high N.A objective with a computer interfaced spectrometer. Microscope performs sample irradiation and signal collection. Laser beam focused by microscope objective irradiates a small spot in the sample. The same objective collects scattered light from the sample and collimates for microscope optics to filter out Raman signals from Rayleigh scattered light and to couple with optical fiber. Spectrometer with either a cooled CCD or PMT as detector analyse signals from the fiber with the help of a computer and software interfaced with the instrument.

Holmarc supplies this Raman instrument along with a vibration isolated table as standard accessory. Depending upon the application requirements, we undertake customization in spectrometer grating, detector and software interface. Invariably, for all orders of this system, our engineers provide installation and service at customer site.



http://www.holmarc.com/confocal_laser_raman_spectrometer.php

Confocal Raman Microscope (CRM)

Specifications

Microscope : Inverted/Upright Infinity Research Grade
Objective : Water immersion 60X with correction collar
Laser wavelength: 532nm & 785nm
Spectral range: 4000 ~ 100cm⁻¹ (Raman)
Spectral Measurement : Scanning
Laser spot size of less than 2 microns
The spectral resolution: 0.65 cm⁻¹.
Wavenumber accuracy: 0.1 cm⁻¹
Detector Unit : High Sensitive PMT & CCD Detector

Application

semiconductor, catalysts, biological, polymers, minerals, corrosion & general purpose

Accessory (Optional)

Mapping sample stage

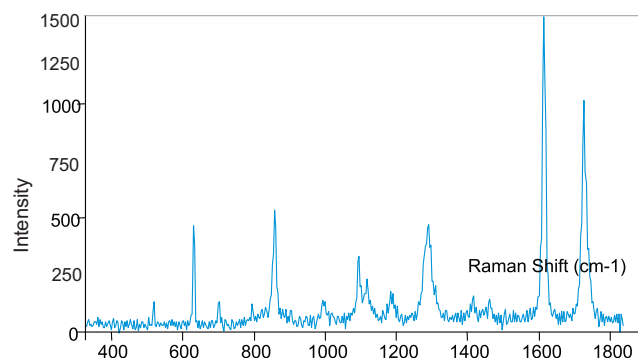

Confocal System using Rod Assembly

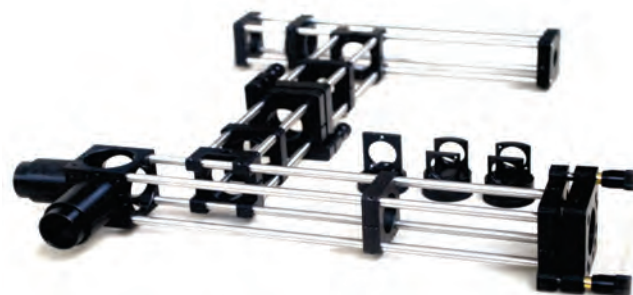

Holmarc provides cost effective solution for setting up confocal system with our rod assembly based components. All the optics can be held precisely along the optical axis using this setup. This provides flexibility for improvisation. The rod assembly system consists of precision ground stainless steel rods with tapped holes at both ends and precision machined plates/cubes having tightly toleranced holes for rods at the corners.

Product customization has been a core service of HOLMARC. Infrastructure and capabilities in mechanics and optics enable us to provide complete in-house services. We can assist in design and development of components as well as complete assemblies. We are dedicated to meet our customer needs by leveraging our years of experience in optics, mechanics and control electronics.

For more information contact us at sales@holmarc.com



FLUORESCENCE Spectrometer

Model : HO-SP-FRS-215Xe

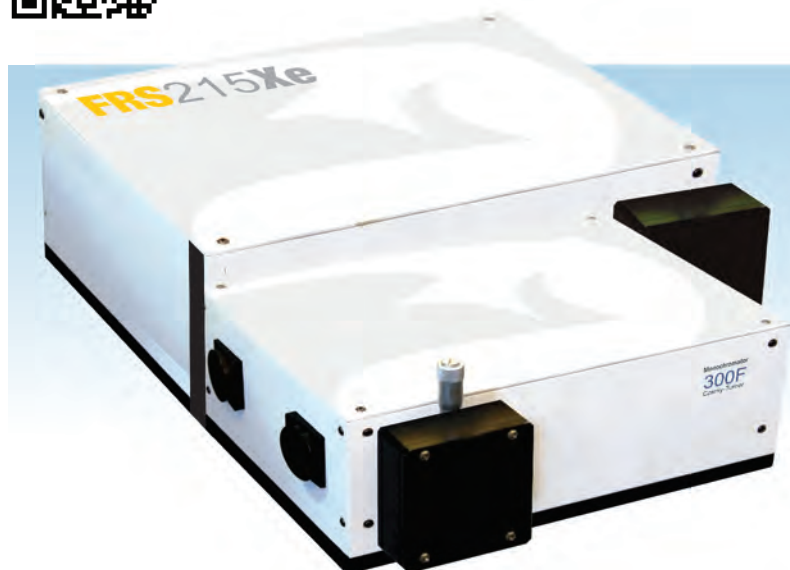

Fluorescence Analysis
UV-VIS-NIR Detection
Research Model Performance
Bio Applications
Raman Spectrum Measurements
Phosphorescence Measurements
Material Analysis
Photometric Measurements
1000 A/lm Min. Luminous Sensitivity
Fast scan speed
Wide dynamic range
Auto-Gain
Automatic Higher-Order Diffraction Cut Filter

Holmarc's fluorescence spectrometer model HO-SP-FRS-215Xe is manufactured for advanced material research as well as for routine biochemical analysis. The instrument incorporates latest designs and techniques in all its eight modules namely source, entrance slit, excitation monochromator, sample chamber, emission monochromator, detector, control electronics and software.

Source

Xenon lamp is used as light source for a standard models. Source can be changed to tungsten halogen or to a combination of deuterium and tungsten-halogen depending upon the application.

Entrance Slit

Entrance slit is micrometer driven with 10 micron resolution and 1 micron sensitivity. Slit width can be adjusted from 0-3 mm. The slit is manually adjusted and locked in position for the experiment.

Excitation Monochromator

Excitation Monochromator has Czerny-Turner design with all the features of our standard device described as model : spectra-UV-VIS-INR . The device incorporates a plane holographic grating with 1200 lines/mm and precision motorized sine drive mechanism. Collimating optics used are concave mirrors to minimize aberrations as far as possible.

Sample Chamber

Sample chamber in the instrument is designed for accommodating 10 mm standard cuvettes. The chamber can be customized on request.

Emission Monochromator

Emission monochromator has similar specifications as that of excitation monochromator. It uses plain holographic grating with motorized wavelength drive mechanism for scanning. Motor used is stepper motor driven in micro-step mode. Collimating optics used are concave mirrors with UV enhanced coating.

Detector

The detector is highly sensitive Photo Multiplier Tubes (PMT) with integrated drive electronics to minimize electronic noise.

Control Electronics

Control electronics takes care of scanning functions of excitation and emission monochromators along with source and detector. Communication with computer is USB based.

Software

The instrument is fully computer based with all operating commands given from the computer. The UI of the dedicated software is made as user friendly as possible. Data is saved in the computer in standard formats.

Specifications

FRS215Xe

Monochromator & Spectrometer

Optical path configuration	: Czerny-Turner type
Focal Length	: 300mm
Aperture Ratio	: f/6
Dispersion element	: Holographic grating
Grating density	: 1200 l/mm
Grating Size	: 50x50mm
Relative diffraction efficiency	: 65 % Max.
Wavelength range	: 190-900nm
Wavelength Selection	: Scanning
Measurement Mode	: Spectra Scanning
Filter Unit	: Automated higher order cutoff filter
Resolution	: ~ 0.1nm
Slit width	: 0-3mm, Micrometer controlled
Dispersion with 300F	: 2.46nm/mm
Wavelength Repeatability	: ± 0.5 nm
Light Source	: 150W Xenon ARC Lamp

Detector Specifications

Detector	: High sensitive PMT Side-on type
Gain Typ.	: 1.0 x 10 ⁷ [Anode]Gain
Control	: Auto Gain
Photocathode Material	: Multialkali
Peak Detection	: 400nm
Luminous Sensitivity Min.	: 140 µA/lm [Cathode]
Luminous Sensitivity Min.	: 1000 A/lm [Anode]
Dark Current (after 30min.)Typ.	: 300 (s-1) nA [Anode]
Software	: Spectra FRS Ver 2.01
Interface	: USB 2.0

Accessories for SPECTRA Instruments



Holmarc regularly designs and manufactures custom spectroscopic accessories for variety of scientific and engineering applications.



- MODEL : HO-SPA-LSL10F**
10W High bright LED Model : 450-650nm
- MODEL : HO-SPA-LSH20F**
20W Halogen Model : 350-2400nm
- MODEL : HO-SPA-LSHD20**
Halogen-Deuterium Model
for UV application 200-2400nm

Fiber optic illumination systems - LED & Halogen-Deuterium - Up to 150W

HOLMARC has expanded its range of fiber optic illumination systems with high-power LED and Halogen-Deuterium light sources. Though designed for use as a stand-alone device, it can easily be mounted on a frame or in a rack using screws. Standard light guide adapter ensures compatibility with all fiber light guides. For efficient coupling, HOLMARC also offers light source with integrated focusing optics for other fiber diameters as well. It can be directly coupled to all spectra products. Deuterium lamp can also be incorporated in this housing for UV applications.



MODEL : HO-SPA-LSMD-OF200
Mercury Discharge Tube Model - std
MODEL : HO-SPA-LSXe-OF200
Xe Arc Lamp Model - 150W

Fiber optic illumination systems - Xenon & Mercury Discharge Tube

This stand-alone illuminator consists of a mercury or xenon arc lamp, lamp housing, mirror and power supply in single enclosure. It is designed to be used with a fiber optic guide which transmits intense illumination to the monochromator, spectrometer and other instruments. The lamp's cabinet accommodates a standard filter wheel which slides easily in and out of a slot in the light path. We also offer a variety of patchcords and collimating optics along with mounts.

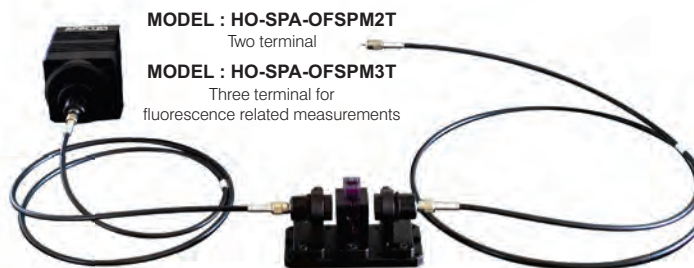

Cuvette holder

Our cuvette holders are for standard 10 mm path length cuvettes to work in UV-VIS-NIR (~200 nm-2 μm) spectral range. These holders have two terminals (Three terminal holders are also available) one fluorescence measurements and one slot for transmittance /absorbance measurements. The embedded collimating lenses are made from fused silica material.



Cuvette holder with fiber optic collimator unit

This fiber optics cuvette holder is designed to attach directly to light sources and can be coupled to spectrometers via optical fibers to create a small-footprint spectrophotometric system for fluorescence and absorbance experiments. The holder is suitable for UV-VIS-NIR (200-1100 nm) applications and holds 10mm square cuvettes. Filter can be directly attached to the system for transmittance/absorbance measurements.

Spectra Light Sources

HOLMARC offers a number of light sources for the spectral range of 200 - 2000nm which can be mounted directly to our monochromators or can be used independently. With the appropriate adapters, some of the light sources can be mounted to our monochromators along with optical chopper or filter wheel. Additional adapters and interface devices are available for focusing and launching the light directly into optical fibers.



http://www.holmarc.com/light_sources.php

Spectral Range



Deuterium
Spectral Range : 200-400nm
Good UV lamp, generally with higher output than Xenon lamps.



Xenon
Spectral Range : 200-2500nm
: 250-2500nm (Ozone free version)



Tungsten Halogen
Spectral Range : 350-2400nm
Continuous spectral output. More stable than Xenon lamps.

Please contact at mail@holmarc.com for more details

Lamp Houses for Spectral Study

Sodium Vapor Lamp

A sodium vapor lamp is a gas discharge lamp that uses sodium in an excited state to produce light. The low-pressure sodium lamp has high luminous efficiency. The radiation is nearly mono-chromatic, yellow in color.

Model : HO-LH-SV35W

Mercury Vapor Lamp

A mercury-vapor lamp is a gas discharge lamp that uses mercury in an excited state to produce light. They offer long life time as well as intense lighting for spectral applications.

Model : HO-LH-MV100W

Multi Spectrum Tube Housing for spectral calibration

MODEL : HO-SP-MSTH-06

HOLMARC's Multi Spectrum Tube Housing holds six spectrum discharge tubes simultaneously. It can quickly switch from one gas to another without handling the tubes. Power supply is common for all discharge tubes, which is kept inside the unit.

The gas tubes are permanently enclosed, which protect the tubes from breakage. Optical fiber can be directly attached to this unit for fiber optic spectrometers.



Spectrum Discharge Tube with Lamp House

Model : HO-SDT-XX

Filled with spectroscopically pure gases. The following discharge tubes are available:

- | | |
|------------|-------------------|
| 01 Argon | 05 Carbon Dioxide |
| 02 Neon | 06 Nitrogen |
| 03 Krypton | 07 Oxygen |
| 04 Ammonia | 08 Mercury vapor |
| | 09 Sulphur |
| | 10 Hydrogen |
| | 11 Helium |

High Voltage Transformer - Continuously Variable

Model : HE-DT-PSV

Variable discharge tube power supplies are designed to be used with different gases. The discharging action is controlled by a knob and can be adjusted to get optimum performance as each gas exhibit different discharge voltages. The complete unit is enclosed in a metallic casing.



Model No: HO-LH-SV

Model No: HO-LH-SVC

Model No: HO-LH-MV

Model No: HO-LH-MD

Model No: HO-LH-DT-02

Model No: HO-LH-ODT-08

SPECTRUM
Sources



Broadband Light Sources

Xenon arc lamp with regulated power supply unit



150 W Xenon arc lamp

Lamp specifications

Quartz Type	: Ozone Free
wavelength range	: 250-2500nm
Wattage	: 150W
Voltage	: 18V
Amperage	: 8.5
Current Range	: 7-8A
Open Circuit Voltage	: 60V
Luminous Flux	: 2900
Luminous Intensity	: 290
Average Luminance	: 20000 lm
Overall Length	: 145mm
Lamp Length	: 125mm
Tip to Shoulder Length	: 57mm
Bulb Diameter	: 20mm
Cathode / Anode Pin	: M4x0.7
Cathode / Anode Base	: 0.39
Arc Length	: 2mm

Lamp Housing : Forced Air Cooled Type
Construction : Metallic

300 W Xenon arc lamp

Lamp specifications

Quartz Type	: Ozone Free
wavelength range	: 250-2500nm
Wattage	: 300W
Voltage	: 20V
Amperage	: 15A
Current Range	: 13-16A
Open Circuit Voltage	: 60V
Average Luminance	: 27000lm
Luminous Flux	: 7000
Luminous Intensity	: 700
Overall Length	: 174mm
Lamp Length	: 150mm
Tip to Shoulder Length	: 63.5mm
Bulb Diameter	: 23.87
Cathode / Anode Pin	: 10-32 UNC-2B
Cathode / Anode Base	: 0.50
Arc Length 0.10	: 2.54mm

Lamp Housing : Forced Air Cooled Type
Construction : Metallic

150 W Xenon arc lamp

Model : HO-SP-XE150

300 W Xenon arc lamp

Model : HO-SP-XE300

Xenon Arc lamps are excellent sources of continuous light. The bright emission from short arc between the anode and cathode makes these lamps high intensity point sources, capable of being collimated with the proper lens configuration or re imaged onto a fiber bundle.

In both models xenon arc lamp housing utilizes heat conductive forced air cooling technique, to make sure efficient cooling of the lamp and electronics. Lamp housing include condensing optics to produce a 25mm collimated light beam. 50mm collimated light beam can also be provided upon request.

Deuterium Lamp with power supply unit

Deuterium lamps are excellent sources of high intensity ultraviolet radiation ranging from 185nm to 400nm. Emission in visible and infrared regions are negligible. This makes deuterium lamps ideal sources for UV spectroscopy, and as UV spectral irradiance standards.

Deuterium Lamp Housing has condensing lens assembly that collects and collimates the lamp's radiation. Output is a 25 mm diameter beam.

Lamp specifications

Lamp : Deuterium
Wavelength range : 185-400nm
Powersupply : Fixed Constant Current Switch Mode Power Supply
Lamp Housing : Forced Air Cooled Type
Construction : Aluminum
Collimation & Collection Optics Dia : 25mm



MODELS	Source
HO-SP-DL20	20W Deuterium
HO-SP-DHL20	20W Deuterium & 20W Halogen Lamp Selection by flip mirror.

Quartz Halogen Lamp with power supply unit

Quartz Halogen lamps are popular alternative to arc lamps which have better output stability without strong UV light emission. Quartz Halogen lamps are preferable for radiometric and photometric applications as well as excitation sources of visible to NIR light. The lamp housing is equipped with cooling vents that allow convection currents to bathe the lamp with cool air during operation. A metallic lining inside the lamp house assists the spherical reflector to direct the maximum possible level of luminous flux into the collector lens system to the microscope optical train.

Lamp specifications

Lamp : Quartz Halogen
Wavelength range : 340-2700nm
Powersupply : Constant Current Switch Mode Power Supply
Supply : Fixed
Lamp Housing : Forced Air Cooled Type
Optical Element : Concave metallic mirror for filament refocusing
Construction : Aluminium
Collimation & Collection Optics Dia : 25mm



MODELS	WATTAGE
HO-SP-QHL150	150W
HO-SP-QHL100	100W
HO-SP-QHL50	50W
HO-SP-QHL20	20W
HO-SP-QHL10	10W

Dual Gooseneck LED Illuminator - 2000 lumens Ultra Bright

Model : HO-SP-DGL2000



Dual Gooseneck LED Illuminator has two flex and stay arms. These LED light units with intensity control give maximum light output of 2000 lumens. Each arm has 1000 lumens output white LED and focus lens. The arms are 300 mm long and there is on/off and dimmer switches to provide fine control. This unit exhibits good control and even illumination. Color temperature is 3200 degree kelvin.

Specifications :

Source	: LED CREE XM
Light output	: 2000 Lumen Max
Colour Temperature	: 3200 degree kelvin
Luminosity control	: Continuously Variable 0-2000 lm
LED Collimation Tube Dia	: 24mm
Flex Arm Length	: 300mm
Finish	: Black Anodized
Power input	: 230V/50Hz

High Bright LED Capsule

For ease of mounting special ultra luminous intensity LED's are housed in metallic casing. The collimating optics in front of the LED helps to get focused beam to increase its lighting efficiency. As the LED is encased in a metallic capsule, the body acts as a heat sink. Brightness is continuously adjustable. This is ideal for a variety of illumination applications where collimated light is required. Various colour options are available.

Specifications :

LED power:	900Lumen
Colour:	Red, Blue, Green, White
Luminosity control:	Front panel knob
LED capsule:	Aluminium
Finish:	Anodized
Power supply:	Built-in
Power input:	230V/50Hz



Model No: HO-HBL-Y

Y - COLOR - R/Y/B/G/W



LASERS

Diode Laser



Holmarc diode laser module consists of a laser diode along with collimating optics enclosed in a metallic case and a power supply with Automatic Power Control (APC). The laser module has 25mm diameter and 50mm length so that it can be held conveniently in kinematic or rigid mount. Collimating lens is an aspheric lens with anti-reflection coating. The soft start feature of the power supply assures smooth switch on and long life.

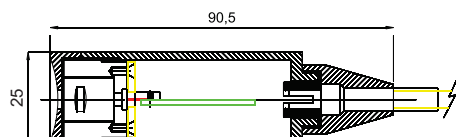

DL Series



	3mW Red diode laser	5mW Red diode laser	5mW Green diode laser	10mW Blue-violet laser
Model No	DL-R-3	DL-R-5	DL-G-5	DL-BV-10
Wavelength	650 nm	650 nm	532 nm	405 nm
Optical Power	3 mW	5 mW	5 mW	10 mW
Supply Voltage	230 VAC / 110 VAC	230 VAC / 110 VAC	230 VAC / 110 VAC	230 VAC / 110 VAC
Operating Current	28 mA	36 mA	< 300 mA	< 800 mA
Working mode	Continuous light	Continuous light	Continuous light	Continuous light
Operating Temperature	10°C~35°C	10°C~35°C	10°C~35°C	10°C~40°C
Storage Temperature	0°C~50°C	0°C~50°C	0°C~50°C	0°C~50°C
Spot Size	5.5x2.5mm	5.5x2.5mm	3x2.5mm	3x2.5mm
Lifetime	> 3000 hrs	> 3000 hrs	> 3000 hrs	> 2000 hrs
Body material	Aluminium	Aluminium	Aluminium	Aluminium

Elliptical Gold Coated Metal Mirrors



We have expertise in making mirrors in stainless steel.

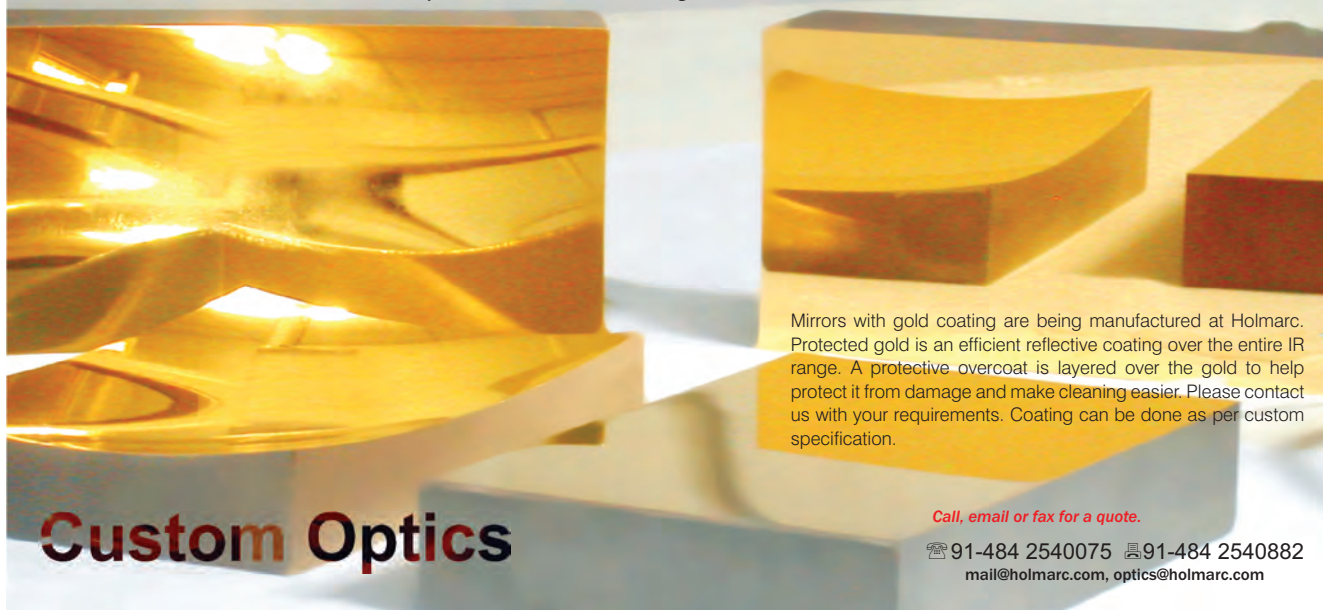

Mirrors with gold coating are being manufactured at Holmarc. Protected gold is an efficient reflective coating over the entire IR range. A protective overcoat is layered over the gold to help protect it from damage and make cleaning easier. Please contact us with your requirements. Coating can be done as per custom specification.

Call, email or fax for a quote.

☎ 91-484 2540075 ☎ 91-484 2540882
mail@holmarc.com, optics@holmarc.com

Custom Optics

DPSS Lasers



Diode Pumped Solid State (DPSS) lasers are more compact and efficient lasers, generally have a higher beam quality and can reach very high powers while maintaining a low divergence and small beam diameter. Because the crystal pumped by the diode acts as its own laser, the quality of the output beam is independent of that of the input beam. DPSS lasers exhibit excellent output stability, exceptional mode purity and extremely low power consumption. They are ideal choice for many laboratory applications.

Specifications :

Operation Mode:	CW 523nm, TEM ₀₀
Line Width:	<0.1nm
Linear Polarization:	> 100:1
Beam Diameter (1/e ²):	<1.2mm
Beam Divergence (1/e ² , Full Angle):	<1.5mrad
Power Stability:	<5% (RMS, over 2 hours)
Point Stability:	0.05mrad
Operating Temperature:	10°C ~ 30°C
Expected Operating Lifetime: ...	>5000 hours
Beam Roundness:	>95%



There are mounting holes to facilitate easy mounting to any surface.

Model No	DPSS-G-5	DPSS-G-40	DPSS-G-100	DPSS-G-200
Wavelength	532nm	532nm	532nm	532nm
Optical Power	5mW	40mW	100mW	200mW

Features

- ▶ High rated electrical-to-optical conversion efficiency
- ▶ Excellent laser beam quality
- ▶ Stable output laser power ± 1% stability
- ▶ Low maintenance or maintenance-free
- ▶ Long diode lifetime – typical to 10,000hrs
- ▶ Compact in size

Applications

- ▶ Atmospheric Science
- ▶ Biophotonics
- ▶ Raman Spectroscopy
- ▶ Holography
- ▶ Interferometry
- ▶ Underwater Imaging & Surveying
- ▶ Fluorescence excitation
- ▶ Optical Communication
- ▶ Flow Cytometry
- ▶ Medical & Chemical Devices
- ▶ Environmental Sensing

DPSS Laser Mount - (HO-DPSS)



Model No. HO-DPSS-BM01

These mounts are manufactured with mounting holes suitable for DPSS lasers. Three lead screws supported kinematic design of the mount enables tilt as well as linear adjustments. The base of the mount has holes suitable for breadboard mounting.

- ▶ Tilting range +/- 2 degrees
- ▶ Driven by 80 tpi leadscrews
- ▶ 20 arc sec. sensitivity
- ▶ Aluminium alloy
- ▶ Black anodized finish
- ▶ Breadboard mountable



Fig. DPSS Laser with Kinematic mount

DPSS Laser Mount - (HOM-DPSS)

Model : HOM-DPSS-G-15090 & HOM-DPSS-19090



These mounts are manufactured with mounting holes suitable for DPSS lasers. Three lead screws supported by the kinematic design of the mount enables tilt as well as linear adjustments. The base of the mount has holes suitable for breadboard mounting.

- ▶ Tilting range +/- 2 degrees
- ▶ Driven by 80 tpi leadscrews
- ▶ 20 arc sec. sensitivity
- ▶ Aluminium alloy
- ▶ Black anodized finish
- ▶ Breadboard mountable

Refer Page 105 for more details about HOM-DPSS Laser Mount



Helium Neon Lasers

Most common and inexpensive gas laser, the helium-neon laser is usually constructed to operate in the red at 632.8nm. Collimation of the beam is accomplished by mirrors on each end of an evacuated glass tube which contains about 85% helium and 15% neon gas at 1/300 atmospheric pressure.

Holmarc's HeNe laser tubes are designed with a built-in voltage transformer. The rectangular housing incorporates a hard-sealed internal mirror and plasma tube design that maximizes the lifetime of the laser. The power cord and on/off rocker switch are located on the back of the housing. Depending on the power output of the laser, the tube may vary in size.

The laser is constructed in such a way that it is safe to use under any circumstances. Laser tube along with its power supply is housed in thick powder coated aluminium box.



He-Ne laser advantages

He-Ne lasers provide superior optical characteristics. While laser diodes must take advantage of external optics to yield a high quality output beam, He-Ne output is well-collimated and does not require external optics. He-Ne lasers also offer excellent coherence lengths (10cm to several meters).

Specifications :

Optical power:	2/5/10/12 mW
Polarization:	Random/Linear
Operating wavelength:	632.8 nm (RED)
Beam diameter:	0.8 mm
Beam divergence:	<=1m rad
Mode:	TEM ₀₀
Output power stability:	+/- 2.5%
Power input:	220V AC, 50Hz
Min. operating lifetime:	15,000 Hrs



Randomly Polarized He-Ne Laser

Optical Power : 2mW, 5mW, 10mW, 12mW

Model No: HL-RP-2, HL-RP-5, HL-RP-10, HL-RP-12

Linearly Polarized He-Ne Laser

Optical Power : 2mW, 5mW, 10mW, 12mW

Model No: HL-LP-2, HL-LP-5, HL-LP-10, HL-LP-12

3D Magnetic Field Mapper

Model : HO-3DMFM-150

HOLMARC's Magnetic Field Mapper measures the magnetic field around magnetized material, permanent magnets and electromagnets. Fields are measured using precision Hall Probe (InAs) sensor along with the MTS series XYZ motorized translation stages. System generates a 3D map of the magnetic field, measures magnetic angle, field homogeneity, etc. It can be used for mapping field uniformity between the poles of electromagnet.

We can provide instrument for 3D magnetic field scan measurement from 0.1Gs to 20000Gs of magnetic field with a precision of ±0.5 Gs. Standard scanning volume range is 150x150x150mm. Spatial measurement (Probe positioning) resolution is ±5 micron. The field data's can be converted to desired magnetic units and stored in a text file in XYZ format.

We can provide Magnetic field mapping instruments for scanning volume up to 500x500x500mm range.

XYZ
Field Mapping
Measurement Range
150mm

Field
Measurement
Resolution
±1Gs

Magnetic Field
Measurement
Range
1Gs to 20,000Gs

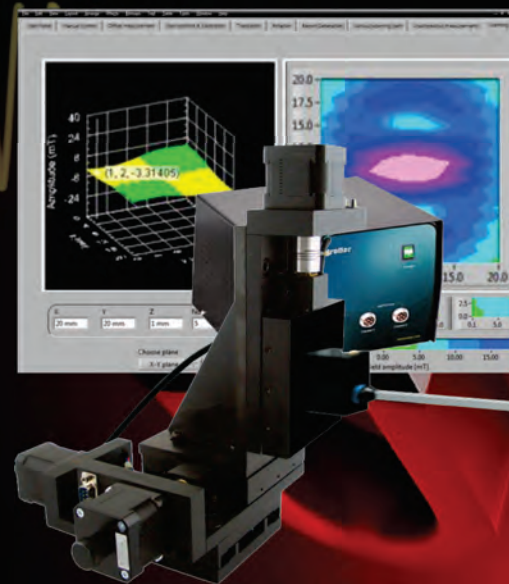

HOLMARC Measuring Instrument





Spectroscopic Line CCD camera Module - Board-Level 3648 Pixel, 16-bit, USB 2.0

Board-Level MODELS : TLC-3648G | TLC-3648WL | TLC-3648FS

HOLMARC's TLC-3648 Series board-level line CCD cameras are compact, cost-effective high-performance B/W camera, based on a TOSHIBA 3648-pixel single-line CCD chip with USB2.0 interface. Ideal for a variety of OEM applications in industry process control, optical spectroscopy and bio-medical imaging, line scanning etc. This camera is an excellent choice for light challenged applications. It can also be used to capture two-dimensional images by moving the object or the CCD. High optical linear resolution can be achieved with scanning techniques. A full-featured SDK driver is also available.

Window-less and fused silica window version of TLC-3648 is available for UV extended wavelength range requirements. TLC-3648WL cameras are window-less version of Toshiba TCD1304DG. In which glass window removed from the image sensor to achieve more sensitivity in ultraviolet region (wavelength range down to 200nm). Window-less models are more suitable for applications that involve coherent light sources like laser line scanning.

Line Scan Camera Specifications:

CCD : Toshiba TCD1304DG
Number of Pixels : 3,648
Pixel Size : 8um x 200um
Sensor Length : 29.18mm

Spectral Range for different models
TLC-3648G : 320nm to 1,000nm
TLC-3648WL** : 200nm to 1,050nm
TLC-3648FS : 200nm to 1,000nm

Pixel Output Clock : 0.5 MHz
Data Storage on Camera : 4 Frames
ADC Resolution : 16 bits
Exposure Time Range : 0.1ms – 6,500ms
GPIO : Yes (4 programmable I/O's)
Frame Rate : 138 scans/second*
Host Interface : USB 2.0

* Frame Rate is dependent on exposure time. When exposure time is set to 0.1ms, the camera can achieve 138 scans/second.

** WL - Without any cover glass on the camera sensor, FS - Fused silica glass window, G - Glass window.

Board-level Line Scan Camera

MODEL	Window Type	Wavelength Range
TLC-3648G	Glass	320-1000
TLC-3648WL	Window less	200-1050
TLC-3648FS	Fused Silica	200-1000

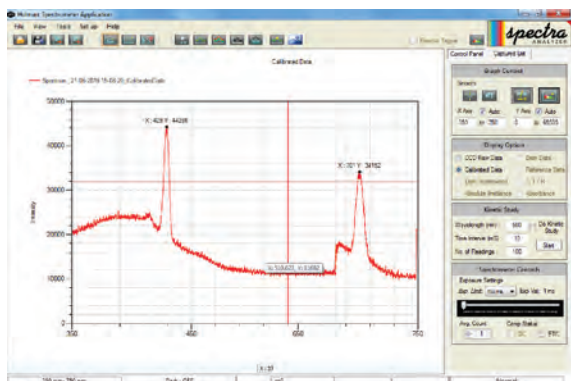

Applications:
Industrial Process Control
Optical Spectroscopy
Image Scanning
Beam Deviation Measurements

Features:

- ▶ USB2.0 compatible
- ▶ Board-level camera, ideal for OEM applications
- ▶ No external power supply required
- ▶ Optical integration time adjustable from 0.1ms to 6.5s
- ▶ 3648 pixel silicon linear CCD array
- ▶ 8um x 200um pixel size
- ▶ Compatible to Windows 7, 2000, XP or higher
- ▶ 16-Bit A/D converter for high intensity resolution
- ▶ High scan rate (up to 138 scans/second)
- ▶ SDK for user applications

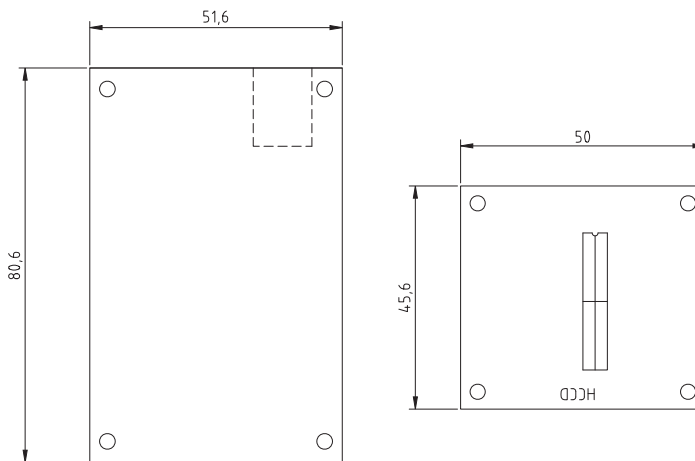

Spectroscopic Line CCD camera Module - Enclosed 3648 Pixel, 16-bit, USB 2.0

MODELS TLCE-3648G | TLCE-3648WL | TLCE-3648FS

Applications:
Industrial Process Control
Optical Spectroscopy
Image Scanning
Beam Deviation Measurements



HOLMARC's TLCE-3648G line CCD camera is a compact, cost-effective high-performance B/W line camera, based on a TOSHIBA 3648-pixel single-line CCD chip with USB2.0 interface. Ideal for a variety of OEM applications in industry process control, optical spectroscopy and bio-medical imaging, line scanning etc. This camera is an excellent choice for light challenged applications. It can also be used to capture two-dimensional images by moving the object or the CCD. High optical linear resolution can be achieved with scanning techniques. A full-featured SDK driver is also available.

TLCE-3648WL cameras is window-less version of TLCE-3648G. In which glass window removed from the image sensor to achieve more sensitivity in ultraviolet region (wavelength range down to 200nm). Window-less models are more suitable for applications that involve coherent light sources like laser line scanning. Fused silica window version is also available for UV applications.

Features:

- ▶ USB2.0 compatible
- ▶ No external power supply required
- ▶ Optical integration time adjustable from 0.1ms to 6.5s
- ▶ 3648 pixel silicon linear CCD array
- ▶ 8um x 200um pixel size
- ▶ Compatible to Windows 7, 2000, XP or higher
- ▶ 16-Bit A/D converter for high intensity resolution
- ▶ High scan rate (up to 138 scans/second)
- ▶ SDK for user applications

Line Scan Camera Specifications:

CCD : Toshiba TCD1304DG
Number of Pixels : 3,648
Pixel Size : 8um x 200um
Sensor Length : 29.18mm

Spectral Range for different models

TLCE-3648G : 320nm to 1,000nm
TLCE-3648WL : 200nm to 1,050nm
TLCE-3648FS : 200nm to 1,000nm

Pixel Output Clock : 0.5 MHz
Data Storage on Camera : 4 Frames
ADC Resolution : 16 bits
Exposure Time Range : 0.1ms – 6,500ms
GPIO : Yes (4 programmable I/O's)
Frame Rate : 138 scans/second*
Host Interface : USB 2.0

Enclosed Line Scan Camera

MODEL	Window Type	Wavelength Range
TLCE-3648G	Glass	320-1000
TLCE-3648WL	Window less *	200-1050
TLCE-3648FS	Fused Silica	200-1000

* Without any cover glass on the camera sensor

* Frame Rate is dependent on exposure time. When exposure time is set to 0.1ms, the camera can achieve 138 scans/second.

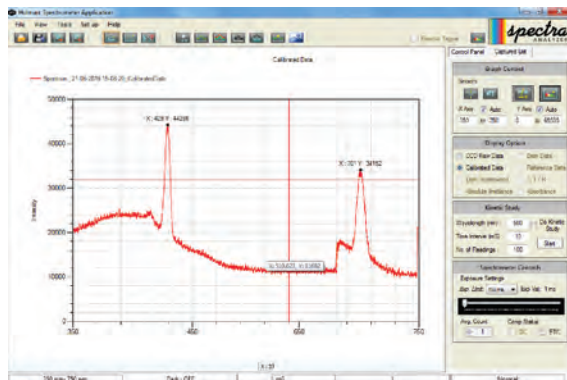

These line cameras are designed for use in a wide variety of spectroscopic and line scanning applications. -30 degree cooled models and custom form factor (sizes) available on request.

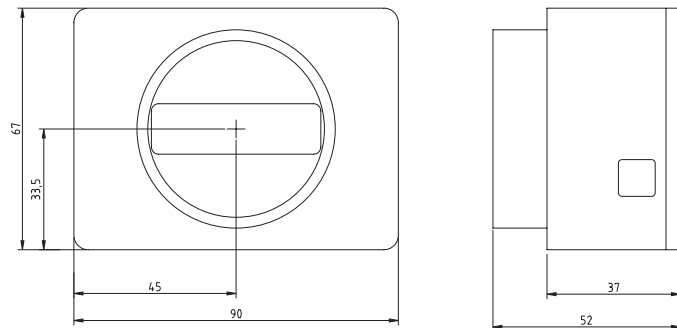

Custom Design team is dedicated to help you to meet your testing needs. We design our own circuit boards and fabricate them from our stock of high quality components sourced internationally. Our core competency is electronic mechanical assembly.

Standard Lens Adaptor for Spectroscopic Line Enclosed CCD camera Module



These lens adaptors allows easy integration of Nikon F-Mount lenses or Sony E - Mount lenses or Canon FL-Mount lenses into spectroscopic line CCD camera body (TLCE-3648). Adapter rings are engraved with an alignment mark. Lense can be lock in place with a spring-actuated lever.

CCD Line Scan Camera Standard Lens Adaptors

MODEL	Adaptor Type	Flange to Sensor Distance
AD-TLCE-FM	F - Mount	46.5mm
AD-TLCE-EM	E - Mount	18mm
AD-TLCE-FLM	FL - Mount	44mm

* CCD Line Camera Accessory - Adaptor, line scan camera sold separately.

High Sensitivity Cooled CCD Camera

6.1MP Cooled CCD Camera

Model : HO-HSCCD-A6.1



HO-HSCCD-A6.1 is a large size 1.8" sensor camera that integrate with advanced peltier cooling technology. It offers a comprehensive guarantee for low light imaging with negligible dark current noise. Cooled camera utilize professional CCD image sensor. Up to 65% quantum efficiency guarantees high-sensitivity performance. Even the ultra-weak optical signal can be detected with this camera.

Specifications

Sensor	: Sony ICX413AQ Color
Sensor size	: 1.8" (25.10mm x 17.64mm)
Pixel size(μm)	: 6.45 x 6.45
Effective pixels	: 3032 x 2016
CCD scan mode	: Interline
Pixels	: 7.8micron x 7.8micron
G sensitivity	: 1000mV
Optical port	: T-mount
Maximum fps	: 2.5fps(3020 x 2016) 10fps (720 x 400) ROI mode
Low-speed readout	: Yes
A/D conversion	: 12 bit (16-bit application data)
Peltier cooled	: -30°C below ambient
Power supply	: 3.5V external power supply
Exposure control	: automatic/manual
Exposure time	: 0.1ms-60minute
Gain	: 6.88 dB in hardware
Overall System Gain	: 8.5135 e/ADU
Readout Noise	: 5.7 e
Maximum Level	: 4095.0 ADU
Full Well Capacity	: 34863 e (minimum)
Dynamic Range	: 75.8 dB
Signal to Noise Ratio	: 45.4 dB
Data interface	: USB2.0/480Mb/s

Overview

- >> Super Large Size 1.8" CCD Sensor
- >> Scientific grade CCD sensor chip ICX413AQ
- >> 6.1MP resolution (3032 X 2016)
- >> 7.8μmX7.8μm pixel size
- >> -30°C below ambient
- >> Data output : 12-bit or 8-bit raw,jpg,bmp
- >> Exposure time : 1ms to over 1 hour



Standard Lens Adaptors for HO-HSCCD-A6.1 cooled camera

MODEL	Adaptor Type	Flange to Sensor Distance
HSCCD-FM	F - Mount	46.5mm
HSCCD-EM	E - Mount	18mm
HSCCD-FLM	FL - Mount	44mm

Microscope Eyepiece super plan achromatic Adaptor for HO-HSCCD-A6.1 cooled camera

MODEL	Adaptor Type	Design
HSCCD-ELA	Microscope Eyepiece Adaptor	Super plan Achromatic 8 Element

* Accessory - Adaptor Models, camera sold separately.



Large Aperture Laser Modulators - Modulation systems Magneto & Electro-Optic

Choose from our line of modulators and driver electronics

HOLMARC now manufactures light modulators, isolators, driver electronics, and associated components to satisfy your diverse requirements.

Optical Modulator & Isolators

Faraday Modulator - Polarization Modulation

In Faraday Effect, the phase modulation of two mutually perpendicular components of linearly polarized light results polarization modulation, which is then transformed into Amplitude Modulation by analyzer. The magneto-optic modulators are based on the rotation of optical polarization as light propagates along the magnetic field in a material, by the Faraday effect. Like intensity modulation, polarization modulation does not require sophisticated stabilized laser. Since, optical sensitivity of a polarization modulated light is about twice as high as intensity modulated signal, it provides better receiver Signal to noise ratio (SNR).

Our modulator is made of MR3-2 Faraday material placed inside a solenoid coil with modulating electric current. Water cooling system is used for longer operation, for which water inlet and outlet connectors are provided on top of the device.

Applications,

- Optical Rotation Measurements
- Magneto-Optic Kerr Effect
- Faraday Modulation Spectroscopy
- Optical Communication



Fig. HO-FM20C Faraday Modulator

Since glass material in high power laser system may be damaged as a consequence of self-focusing, low non-linear refractive index as well as high Verdet constant are considered important factors for Magnetic Optical Glass. The MR3-2 glass is made by satisfying all these factors is stable, sensitive and inherently immune to interference.

The optical Specifications :

- Faraday Rotator Glass : MR3-2 glass
- Verdet constant: $-0.329 \text{ min/Oe} \cdot \text{cm}$ at 632.8nm and $-0.108 \text{ min/Oe} \cdot \text{cm}$ at 1064nm
- Absorption coefficient: $< 0.002 \text{ per cm}$ at 1064nm
- Transmission: $\geq 86\%$ without AR coating
- Bulk laser damage threshold for material : $> 25 \text{ (Joules/cm}^2\text{)}$ at 1064nm, 10ns pulses
- For stress birefringence, extinction ratio to perpendicular polarization $> 40 \text{ dB}$

Model	Aperture	Wavelength Range (nm)	Frequency Range (Hz)	Resolution : +/-1Hz
HO-FM05C	5mm	380 - 1100nm		
HO-FM10C	10mm			
HO-FM015C	15mm		200-5000Hz	
HO-FM20C	20mm			



The Faraday modulator used for the polarimeter has important functions other than providing easy way of optimizing the signal to noise ratio; it allows the real and imaginary parts of the refractive indices to be separated. This stems from the fact that in the modulator there is very little absorption i.e. the effect is only to modulate the angle of rotation of the linearly polarized laser beam with negligible modulation of the phase or ellipticity of the light.



Fig. Water Cooler for Faraday Modulator

Faraday Isolator (Optical Isolator)

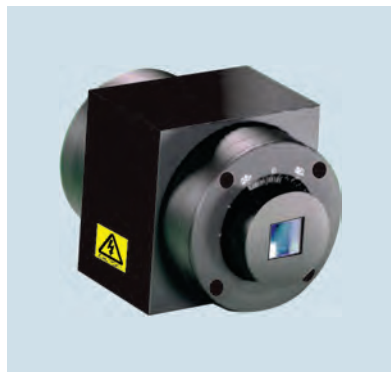

Faraday isolators are optical components which allow light to travel only in one direction. Their mode of operation is based on non-linear Faraday effect (magneto rotation). In principle, the function of an optical isolator is analogue to that of an electrical diode. Faraday isolators are composed of three elements: entrance polarizer, Faraday rotator and exit Polarizer.

It is used to protect a laser source from destabilizing feedback or actual damage from back-reflected light. The 5mm aperture Faraday isolators are cylindrically-shaped magneto-optic devices. Strong Neodymium Iron Boron permanent magnets are used to generate axially-oriented fields within the magnet housing. In operation, the magnet housing is sandwiched between input and output polarizers that have their transmission axis oriented 90 degrees relative to each other. In the reverse direction the backward traveling beam has a polarization orthogonal to the input polarizer and is therefore crossed with it, resulting in a rejected beam exiting the input polarizer.

We also provide custom designed isolators, as per requirement. Please feel free to contact us.

Model	Center Wavelength	Aperture	Transmission	Isolation Min/Typical	Polarizer Type	Rotating Medium	Power Handling
HO-FI410	410nm	5mm	80 / 82 %	30 dB	Calcite	MR3-2 Faraday Glass	> 25 (Joules/cm ²) at 1064nm 10ns pulses
HO-FI532	532nm		85 / 89 %	36 / 40 dB			
HO-FI632	632.8nm		85 / 89 %	35 / 38 dB			
HO-FI650	650nm		85 / 89 %	35 / 38 dB			
HO-FI785	785nm		85 / 89 %	35 / 38 dB			



Optical Chopper

Model No: HO-IAD-OC-01

HOLMARC
Speciality Instrument



An optical chopper is a mechanical device which physically chops a light beam into discrete light pulses. It is widely used in various optical experiments. It modulates different light sources with given frequency for their subsequent analysis.

The chopping discs come in a variety of slot apertures and can be replaced with ease.

Holmarc's optical chopper is a stable device through out the frequency range. The basic system consists of control unit, rotating head and a set of four chopper discs. A DC motor drives the rotating head in closed loop control. Chopping discs are replaceable by the user with ease. A heavy base to which the rotating

assembly is fixed provides stability during operation. Optical axis height is approximately 100 mm. The required disc depending on the frequency can be fixed to the rotating head. This system provide wide range of frequencies (10Hz - 3.7kHz.) A wide selection of additional discs and accessories are available to extend the frequency range and to satisfy individual requirements. Frequency is displayed directly on the digital display of the control unit. Easy-to-interchange blades are made of corrosion protected material for durability.

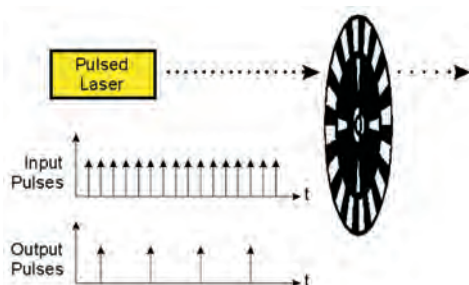
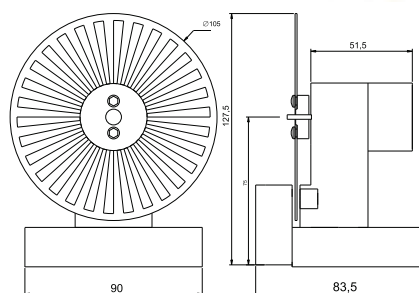

30 Slot Blade



10 Slot Blade



5 Slot Blade



2 Slot Blade

Specifications

Frequency	
Five slot	: 10Hz to 400 Hz
Thirty slot	: 50Hz to 3.7 kHz
Ninety Slot	: 200Hz to 11 kHz (Optional)
Chopper wheel diameter	: 105mm
Stability	: +/- 1 Hz
Frequency read out	: 16X1 line LCD
Reference pick-up	: IR LED and photo transistor pair
Motor cable length	: 2m
Operating temperature	: 10-50°C
Power input	: 230V, 50Hz

Custom single & Dual frequency blades Available for up to **11 kHz** Chopping Applications

Custom Single and Dual Frequency Optical Chopper Blades can be also manufactured. We welcome queries for customization.

SMA 905 0.22NA FUSED SILICA Fiber optic patchcords

HOLMARC offers multimode step index fiber optic patch cables with SMA905 connectors on both ends and are ideal for applications requiring optimum transmission in the UV-VIS range (190 - 1600nm). These cables incorporate fused silica (0.22 numerical aperture) fiber, sheathed in rugged 3/16" OD PVC monocoil and are available in 1.5m length. Each patch cable includes two protective caps that shield the connector ends from dust and other hazards.

Fiber Specifications

Wavelength : UV/VIS/NIR
Wavelength Range : 190 - 1600nm
Connector : SMA
Numerical Aperture NA : 0.22
Numerical Aperture (NA) Tolerance ± 0.02
Index of Refraction nd - Core : 1.458
Index of Refraction nd - Cladding : 1.441
Acceptance Angle : 25.4°
Operating Temperature : -40 to +100°C
Length : 1.5m
Jacket Diameter : 2.85mm
Jacket Material : PVC Monocoil



Model	Connector	Length	Core Diameter
HO-FOP-FS1505S	SMA 905	1.5 meter	50um
HO-FOP-FS1510S	SMA 905	1.5 meter	100um
HO-FOP-FS1520S	SMA 905	1.5 meter	200um
HO-FOP-FS1540S	SMA 905	1.5 meter	400um
HO-FOP-FS1560S	SMA 905	1.5 meter	600um
HO-FOP-FS15100S	SMA 905	1.5 meter	1000um

Different types and lengths of fibre are available on request.

SMA 905 PMMA 0.5NA Fiber optic patchcords

Multimode High Transmission Fiber optic patchcords for easy integration in Fiber optic test system

HOLMARC can supply high quality PMMA Fiber optic patchcord for low cost fiber coupling and illumination needs. This product is lighting grade and gives good visible light transmission and flexibility.

Polymethyl Methacrylate / Fluorinated Polymer
Single Core Polymer Fiber

Numerical aperture : 0.5
Core Diameter : 750 Micron
Refractive index : 1.49
Refractive index profile : Step index
Wavelength Range : VIS-NIR



Fiber Specifications

Type : Multimode
Cable Diameter : 3 mm
Cable Length: 1, 2, 3 meter or customized
Connector loss: < 0.5 dB
Attenuation: < 180 dB/km
Core material : Polymethyl Methacrylate
Cladding material : Fluorinated Polymer
Refractive index : 1.49
Numerical aperture : 0.5
Refractive index profile : Step index
Connector material : stainless steel sheath/Brass insert core

Operation Conditions
Temperature range : -55°C (-67°F) to +70°C (158°F)
in low humidity; < 60°C at 95% RH
(attenuation change is within 10% after 1000 hours other than the attenuation due to absorbed water).
Please note that fiber becomes brittle at low temperatures.

Model	Connector	Length
HO-FOP-A05	SMA 905	0.5meter
HO-FOP-A10	SMA 905	1 meter
HO-FOP-A15	SMA 905	1.5 meter
HO-FOP-A20	SMA 905	2 meter
HO-FOP-A25	SMA 905	2.5 meter
HO-FOP-A50	SMA 905	5 meter

Rectangular to Circular Fiber Patchcords



The rectangular to circular fiber patchcords has an circular fiber arrays at one end and a rectangular slit like array at the other end. Multiple fiber slit shape arrangement helps to collect more light from a light source to a monochromator or spectrometer or from a monochromator to a detector or sample. The fiber slit array shape at the end can be used to replace the spectrometer/monochromator input slit.



Specifications

Design : Rectangular to Circular Bundle
Numerical Aperture : 0.22 NA for fused silica and glass fiber
0.5 NA for Plastic fiber
Fiber Length : 1 meter
Fiber Connector : SMA 905 Connector and 5mm Ferrule

Slit adaptor and holders can be provided on request. Micrometer controlled slit with rectangular to circular fiber patchcords can be used to adjust band width and light controls.

Model	Material	Optimum Wavelength Range	Numerical Aperture	Total Fibers	Core Diameter / Slit Width	Fiber Slit Height	Connector
HO-RCFB-F600S	Fused Silica	200-1600nm	0.22 NA	6	600um	4.5mm	SMA 905
HO-RCFB-F400S	Fused Silica	200-1600nm	0.22 NA	10	400um	5mm	SMA 905
HO-RCFB-F400F	Fused Silica	200-1600nm	0.22 NA	29	400um	15mm	5mm Ferrule
HO-RCFB-F600F	Fused Silica	200-1600nm	0.22 NA	19	600um	15mm	5mm Ferrule
HO-RCFB-F1000F	Fused Silica	200-1600nm	0.22 NA	7	1000um	8.4mm	5mm Ferrule
HO-RCFB-G600S	Glass	350-1600nm	0.22 NA	6	600um	4.5mm	SMA 905
HO-RCFB-G400S	Glass	350-1600nm	0.22 NA	10	400um	5mm	SMA 905
HO-RCFB-G400F	Glass	350-1600nm	0.22 NA	29	400um	15mm	5mm Ferrule
HO-RCFB-G600F	Glass	350-1600nm	0.22 NA	19	600um	15mm	5mm Ferrule
HO-RCFB-G1000F	Glass	350-1600nm	0.22 NA	7	1000um	8.4mm	5mm Ferrule
HO-RCFB-P750S	Plastic	400-1300nm	0.5 NA	5	750um	4mm	SMA 905
HO-RCFB-P750F	Plastic	400-1300nm	0.5 NA	15	750um	12mm	5mm Ferrule

Note : Product specifications are subject to change without prior notice.

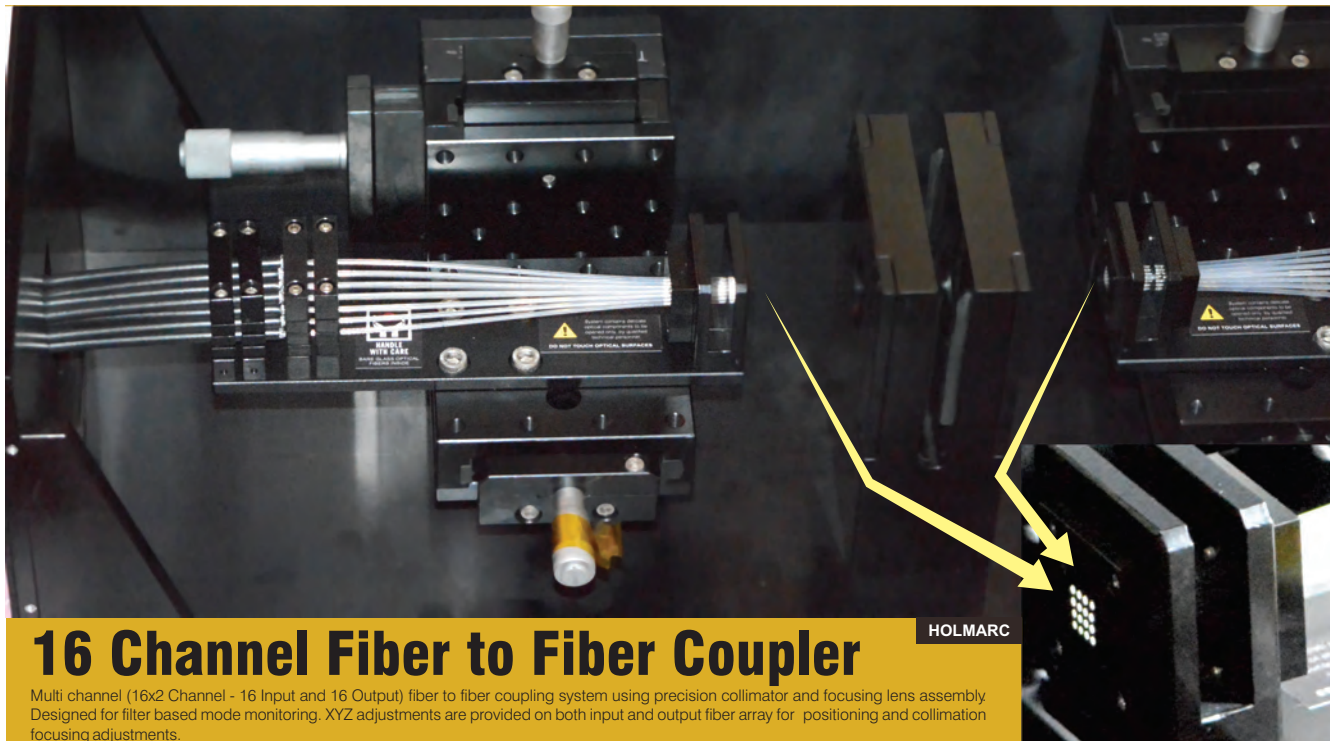

16 Channel Fiber to Fiber Coupler

Multi channel (16x2 Channel - 16 Input and 16 Output) fiber to fiber coupling system using precision collimator and focusing lens assembly. Designed for filter based mode monitoring. XYZ adjustments are provided on both input and output fiber array for positioning and collimation focusing adjustments.

Reflectance Probes

Reflection/Backscatter Fiber Optic Probe For Spectroscopy



Holmarc's reflection and backscatter fiber optic Probes are designed for a variety of applications including diffuse and specular reflectance, color, fluorescence, and back scattering of solid, liquid, and powder samples. They are bifurcated fiber cables with a leg to carry light from a source to a sample and reflected / scattered light by the sample to a spectrometer.

Reflection probes are available with SMA905 end legs for standard interface or a Ø6.35 mm probe tubing for manual applications. Both types of reflectance probe have light source and spectrometer legs with SMA905 connectors for compatibility with standard fiber optic spectrometers and light source. (Please see our CG216 / CT216 series fiber optic spectrometer and light source).

Probes are available for UV (Fused silica core) and VIS-NIR wavelength ranges. We offer custom probe configurations and accessories for the different scientific applications.

- Color Measurement
- Fluorescence
- Reflectance
- Diffuse and specular reflectance

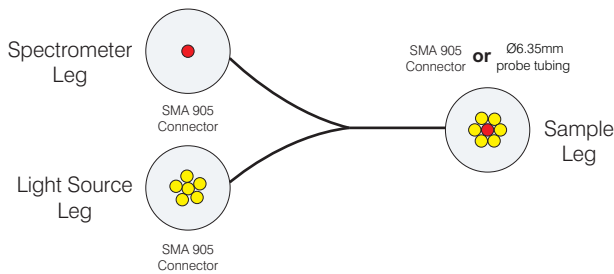

Fig. Reflection probes with SMA905 end legs

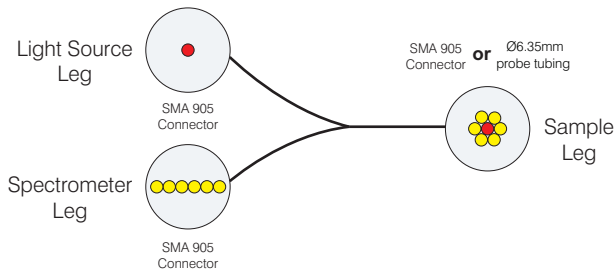

Fig. Reflection probes with Ø6.35 mm probe for manual operations.

Type A Reflectance Probe



Type B Reflectance Probe



SPECIFICATIONS

- Probe ferrule material:Stainless steel
- Probe tube length : 75 mm (3")
- Probe tube diameter : 6.35 mm (1/4")
- Probe fiber bundle : 6 illumination fibers around 1 read fiber for 200micron fiber reflectance probe
5 illumination fibers around 1 read fiber for 400micron fiber reflectance probe
- Numerical aperture : 0.22 N.A
- Jacket : Stainless steel
- Connectors : Precision SMA 905
- Length : 2 m
- Breakout : Midway point of assembly at 1 meter
- Fiber core size : 200um and 400 um (see product table)
- Wavelength range : UV/VIS, VIS/NIR

SMA Terminated Reflectance Probe

Model	Reflectance probe Type	Fiber Core Diameter	Wavelength Range	Leg Connectors	Number of fibers
HO-SP-RP200UA	Type A	200um	200-900nm (UV/VIS)	Light Source : SMA 905 Spectrometer : SMA 905 Sample Leg : SMA 905	Light Source 6 or 1
HO-SP-RP200VA	Type A	200um	320-1900nm (VIS/NIR)		Spectrometer 1 or 6
HO-SP-RP200UB	Type B	200um	200-900nm (UV/VIS)		Sample 6+1
HO-SP-RP200VB	Type B	200um	320-1900nm (VIS/NIR)		
HO-SP-RP400UA	Type A	400um	200-900nm (UV/VIS)	Light Source : SMA 905 Spectrometer : SMA 905 Sample Leg : SMA 905	Light Source 5 or 1
HO-SP-RP400VA	Type A	400um	320-1900nm (VIS/NIR)		Spectrometer 1 or 5
HO-SP-RP400UB	Type B	400um	200-900nm (UV/VIS)		Sample 5+1
HO-SP-RP400VB	Type B	400um	320-1900nm (VIS/NIR)		

Ø1/4" Terminated Reflectance Probe

Model	Reflectance probe Type	Fiber Core Diameter	Wavelength Range	Leg Connectors	Number of fibers
HO-SP-RP200UAP	Type A	200um	200-900nm (UV/VIS)	Light Source : SMA 905 Spectrometer : SMA 905	Light Source 6 or 1
HO-SP-RP200VAP	Type A	200um	320-1900nm (VIS/NIR)		Spectrometer 1 or 6
HO-SP-RP200UBP	Type B	200um	200-900nm (UV/VIS)		Sample 6+1
HO-SP-RP200VBP	Type B	200um	320-1900nm (VIS/NIR)		
HO-SP-RP400UAP	Type A	400um	200-900nm (UV/VIS)	Sample Leg : Ø1/4" Probe	Light Source 5 or 1
HO-SP-RP400VAP	Type A	400um	320-1900nm (VIS/NIR)		Spectrometer 1 or 5
HO-SP-RP400UBP	Type B	400um	200-900nm (UV/VIS)		Sample 5+1
HO-SP-RP400VBP	Type B	400um	320-1900nm (VIS/NIR)		

Type C Reflectance Probe

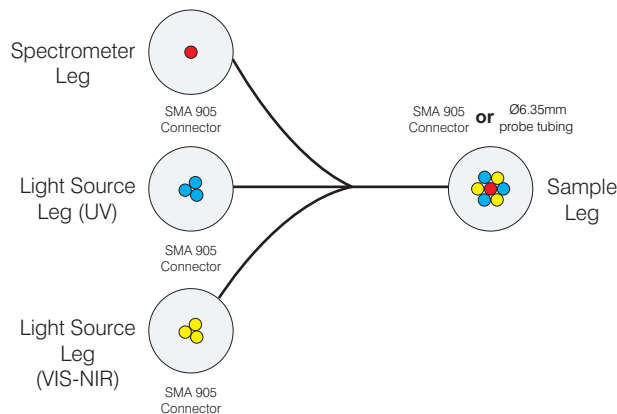

Holmarc's reflection and backscatter fiber optic Type C Probes are designed for working with two different light source. Two light source legs are provided (1 Spectrometer + 2 Light Source + 1 Sample). One of the light source leg fiber is made of UV (Fused silica core) optical fiber for below 400nm application while the other light source leg assigned for VIS-NIR wavelength ranges.

These probes are also available with SMA905 end legs for standard interface or a Ø6.35 mm probe tubing for manual applications. Both types of reflectance probe have light source and spectrometer legs with SMA905 connectors for compatibility with standard fiber optic spectrometers and light source. (Please see our CG216 / CT216 series fiber optic spectrometer and light source).

We offer custom probe configurations and accessories for the different scientific applications.

Type C Reflectance Probe

Model	Fiber Core Diameter	Wavelength Range	Reflectance probe Type	Sample Leg	Number of fibers
HO-SP-RP200UC	200um	200-1900nm (UV/VIS/NIR)	Type C	SMA 905	Light Source Leg Fibers : 6 (3 + 3) (Two independent legs are used)
HO-SP-RP200UCP	200um		Type C	Ø1/4" Probe	Spectrometer Leg Fiber : 1 Sample Leg No. of Fibers : 7 (3+3+1)

Reflectance Probe Stands

Reflectance probe stands are designed to hold fiber optic probes with Ø1/4" probe sample leg. Two models are available RPS-CF and RPS-25XYZ. RPS-CF is Ø140mm base fixed probe holder with engraved grid and concentric circles base. While Model RPS-25XYZ is micrometer controlled probe positioner. Sample and probe can be precisely positioned on desired location.

Both fiber probe stands can be positioned at 90° (for specular measurements) or 45° (for diffuse measurements) with respect to the sample. Optical post for probe adjuster is engraved metric height scale. Up to 60mm height sample can be accommodate.

Motorized XY scanning stage based reflectance probe stand can be provided on request. It can be used for sample thickness 3D profiling.

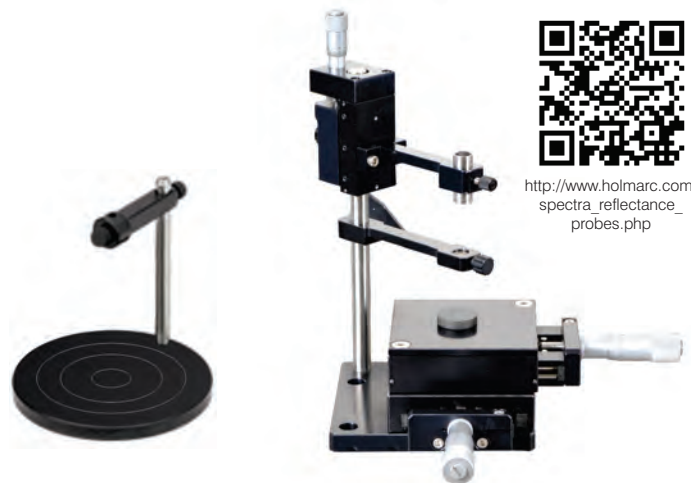

Model : HO-SP-RPS-CF

Model : HO-SP-RPS-25XYZ

http://www.holmarc.com/spectra_reflectance_probes.php

Fiber Optic Transmission Dip Probe



Fiber optic transmission dip probes are primarily designed for the measurement of liquids. It can be submerged into the liquid sample, allowing for kinetic data to be collected. The design of a fiber dip probe is very similar to that of a reflection probe. The key functional difference is the presence of a cavity which, when immersed, fills with the liquid sample. This cavity contains an optically transparent window placed at the distal end of the fiber and a small mirror placed at the bottom of the cavity to reflect the transmitted light back through the sample and into the collection fiber. This method combines transmission and reflection, doubling the optical path length.



SPECIFICATION

Transmission : 0.2 - 1.35 μm (UV-VIS-NIR)
Fiber Core Material : Fused Silica
Temperature Range : 0 - 85° C
Minimum Bending Radius : 120 mm
Total Length : 1.5 m
Shaft Length : 225 mm
Shaft Diameter : 14 mm
Gap Length : 2, 5, 10 & 20 mm

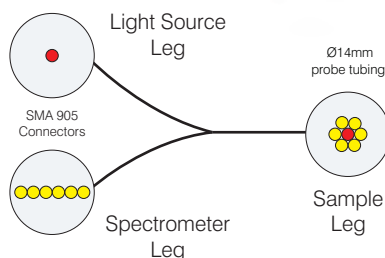

APPLICATIONS

- * Real Time Reaction Monitoring
- * Crystallization Development & Screening
- * Analytical Characterization
- * Biopharmaceutical Analysis

Transmission Dip Probe

Model	Reflectance probe Type	Fiber Core Diameter	Wavelength Range	Leg Connectors	Number of fibers
HO-SP-RDP200UBP	Type B	200 μm	200-1350nm (UV/VIS/NIR)	Light Source : SMA 905 Spectrometer : SMA 905	Light Source 6 or 1 Spectrometer 1 or 6 Sample 6+1
HO-SP-RDP400UBP	Type B	400 μm	200-1350nm (UV/VIS/NIR)	Sample Leg : Ø14mm Probe	Light Source 5 or 1 Spectrometer 1 or 5 Sample 5+1

CT216 Series Compact CCD Spectrometer
MODEL : HO-CT216-3582

or

Spectra Multi Channel Scanning Spectrometer
MODEL : HO-SP-3S300FS
For Multi channel average measurements



Fiber optic illumination systems
20W Halogen (SMA)
MODEL : HO-SPA-LSH20F

Reflectance Probe Stand
MODEL : HO-SP-RPS-CF

Fiber Optic Transmission Dip Probe
MODEL : HO-SP-RDP400UBP

Dip Probe Tips

Dip probe tip is attach to the end of the fiber optic transmission dip probe. The opening of the dip probe tip allows liquid sample to flow freely within the measurement region during a measurement. For repeated uses, probe tips can be cleaned using an ultrasonic cleaner. Tips are available in 5 mm, 10 mm, 20 mm and 40 mm path lengths. A longer path length tips are used for low-absorbance samples while shorter path length tips are useful for resolving high-absorbance samples.

Model	SP-DPT5	SP-DPT10	SP-DPT20	SP-DPT40
Cavity Length	2.5mm	5mm	10mm	20mm
Path Length	5mm	10mm	20mm	40mm